

# Maintenance and Parts Manual

## ADZ Series Suspension

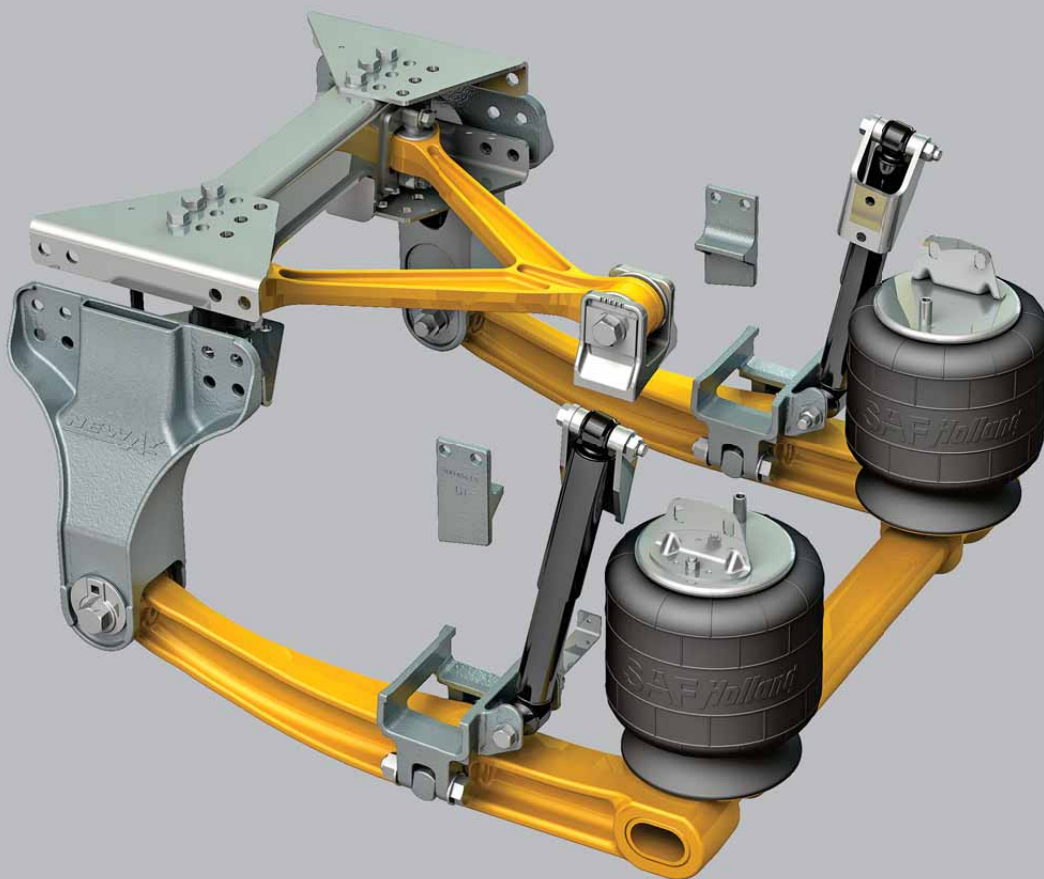



Contents	Page
Introduction .....	3
Warranty .....	3
Notes, Cautions, and Warnings .....	3
Section 1 – General Safety Instructions .....	4
Section 2 – Model Identification and Serial Tag Information .....	5
Section 3 – Model Nomenclature .....	5
ADZ 123 Series Suspension – Exploded View .....	6
ADZ 123 Series Suspension – Parts List .....	7
ADZ 126 Series Suspension – Exploded View .....	8
ADZ 126 Series Suspension – Parts List .....	9
Section 4 – Service Repair Kits .....	10
Section 5 – Pre-Operation .....	12
Section 6 – Ride Height Adjustment .....	14

Contents	Page
Section 7 – Axle Alignment .....	15
Section 8 – Changing Pinion Angle..... Pinion Angle Reference Chart.....	16 19
Section 9 – Air Spring Replacement.....	20
Section 10 – Shock Absorber Replacement .....	21
Section 11 – Axle Adapter Bar-Pin and Pivot Connection Bushing Replacement.....	22 22
Section 12 – V-Rod Bushing Replacement.....	26
Section 13 – Frame Bracket Replacement .....	29
Section 14 – Crossmember End Plate Replacement.....	32
Section 15 – Replacement Procedures .....	32
Section 16 – Torque Specifications .....	38
Section 17 – Routine Maintenance and Inspection .....	39
Section 18 – Troubleshooting .....	40

## Introduction

This manual provides the necessary information for the care, maintenance, inspection, and safe operation of the SAF-HOLLAND® Neway® ADZ Series Air Suspension. The Neway® ADZ Series Suspension is designed and engineered to provide trouble-free service. In the event of minor breakdown, such as a loss of air in the air springs, there are safety features designed into the suspension that will allow the vehicle to be driven CAUTIOUSLY at a slow speed, to the nearest service facility.

This suspension uses air delivered from the truck/tractor air system to pressurize the air springs and is controlled by either one (1) or two (2) height control valves. The height control valve regulates the air pressure required for varying loads and maintains the design ride height.

The Neway® ADZ Series Suspensions are designed to be compatible with disc brake systems.

**NOTE:** For suspension components replacement contact SAF-HOLLAND® Customer Service at 888-396-6501.

## Warranty

Refer to the complete warranty for the country in which the product will be used. A copy of the written warranty can be found on the SAF-HOLLAND® website (www.safholland.us).

## Notes, Cautions, and Warnings

Read and understand all of the safety procedures presented in this manual before starting any work on the suspension/axle.

**NOTE:** In the United States, workshop safety requirements are defined by federal and/or state Occupational Safety and Health Act or equivalent laws in other countries. This manual is written based on the assumption that OSHA or other applicable employee safety regulations are followed by the location where work is performed.

Proper tools MUST be used to perform the maintenance and repair procedures described in this manual. Some of these procedures require special tools.

This manual contains the terms "NOTE", "IMPORTANT", "CAUTION", and "WARNING" followed by important product information. These terms are defined as follows:

**NOTE:** Includes additional information to enable accurate and easy performance of procedures.

**IMPORTANT:** Includes additional information that if not followed, could lead to hindered product performance.

**CAUTION** Used without the safety alert symbol, indicates a potentially hazardous situation which, if not avoided, could result in property damage.

**⚠ CAUTION** Indicates a potentially hazardous situation which, if not avoided, could result in minor or moderate injury.

**⚠ WARNING** Indicates a potentially hazardous situation which, if not avoided, could result in death or serious injury.

## 1. General Safety Instructions

**IMPORTANT:** Read this manual before using this product. Keep this manual in a safe location for future reference.

**⚠ WARNING** Failure to follow the instructions and safety precautions in this manual could result in improper servicing or operation leading to component failure which, if not avoided, could result in death or serious injury.

Read and observe all Warning and Caution hazard alert messages in this publication. The information provided can help prevent serious personal injury, damage to components, or both.

**⚠ WARNING** Failure to properly support the vehicle and/or suspension prior to commencing work could create a crush hazard which, if not avoided, could result in death or serious injury.

Please observe the following safety instructions in order to maintain the operational and road safety of your SAF-HOLLAND® suspension:

1. Always be sure to chock the front tires prior to commencing work to prevent the vehicle from rolling forward or backward.

**⚠ WARNING** Failure to chock the front tires prior to commencing work may allow the vehicle to roll forward or backward which, if not avoided, could result in death or serious injury.

2. The air springs should always be operated with a static operating pressure between 80 psig (5.5 bars) and 100 psig (6.9 bars). The ideal static operating pressure of the air springs is 90 psig (6.2 bars).

**⚠ WARNING** Failure to operate the air springs with a proper static operating pressure could cause premature component failure and loss of vehicle control which, if not avoided, could result in death or serious injury.

3. In the event of an air loss, it is recommended to disconnect the HCV linkage to ensure all air springs are fully deflated. The vehicle can be temporarily operated and the load can be carried on the axle stops. In the event of inadequate air pressure, move the vehicle CAUTIOUSLY, at a slow speed, to the nearest repair facility. To deflate the air suspension, refer to procedures described in this manual. Before transporting the vehicle to a service center, check tire clearances. DO NOT operate the vehicle if any tire(s) is rubbing the vehicle.

**⚠ WARNING** Failure to maintain clearance between tires and the nearest point of contact on the suspension or vehicle could cause fire or loss of vehicle control which, if not avoided, could result in death or serious injury.

We highly recommend the use of only SAF-HOLLAND® Original Parts.

A list of SAF-HOLLAND® technical support locations to supply SAF-HOLLAND® Original Parts can be found at [www.safholland.us](http://www.safholland.us) or you can contact SAF-HOLLAND® Customer Service at 888-396-6501.

Updates to this manual will be published as necessary online at [www.safholland.us](http://www.safholland.us).

## 2. Model Identification

A serial tag and model number tag are attached to the left and right ends of the transverse beam (lower control arm assembly) (**Figure 1**). The tags supply valuable information regarding the exact components used to manufacture the suspension (**Figure 2**).

**NOTE:** Depending upon chassis builder configuration, the model number tag may not call out the exact kit or parts list number. If so, the vehicle chassis builder will be able to identify the suspension model and its components using the vehicle's VIN number.

**IMPORTANT:** Due to the custom built nature of each Neway® ADZ application, having the exact parts list used by the chassis builder is critical in determining proper replacement components.

It is recommended to determine the specific model number, record the information (**Figure 3**), and refer to it when obtaining information or replacement parts.

## 3. Model Nomenclature

**IMPORTANT:** This manual applies to the suspension model series listed below and for special orders of the same. It is very important to determine the specific model number, serial number, and parts list number. Record those numbers on this page, and refer to them when obtaining information or replacement parts.

Single Axle:	Tandem Axle:	Tridem Axle:
ADZ-123	ADZ-246	ADZ-369
ADZ-124*	ADZ-248*	
ADZ-126	ADZ-252	ADZ-378
ADZ-127*	ADZ-254*	

\*Denotes special increased capacity for fire apparatus applications only with SAF-HOLLAND® Engineering approvals.

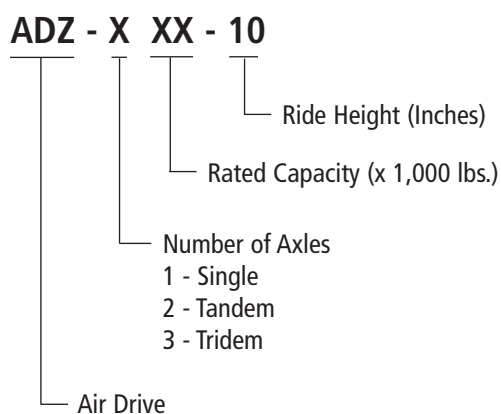

Figure 1

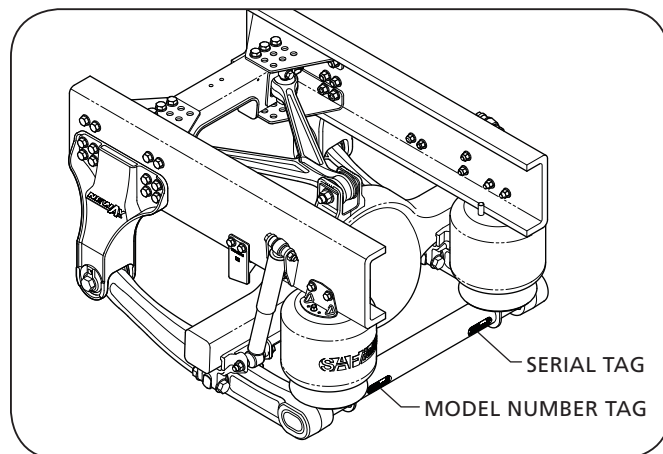

Figure 2

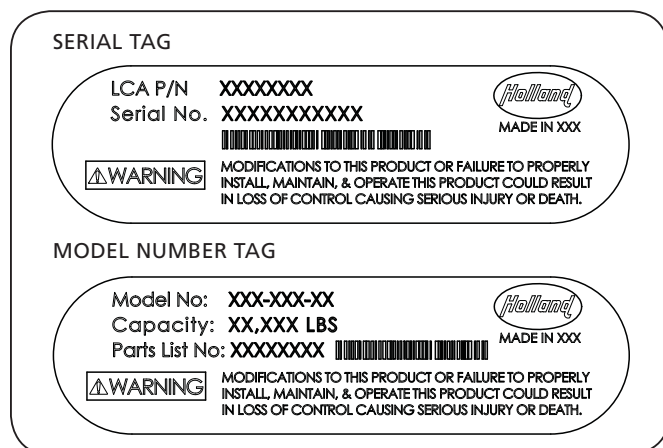

Figure 3

**Write Important Suspension Data Here:**

LCA Serial Number: \_\_\_\_\_

Model Number: \_\_\_\_\_

Parts List Number: \_\_\_\_\_

In Service Date: \_\_\_\_\_

# ADZ 123 Series Suspension - Exploded View



SAF-HOLLAND Group

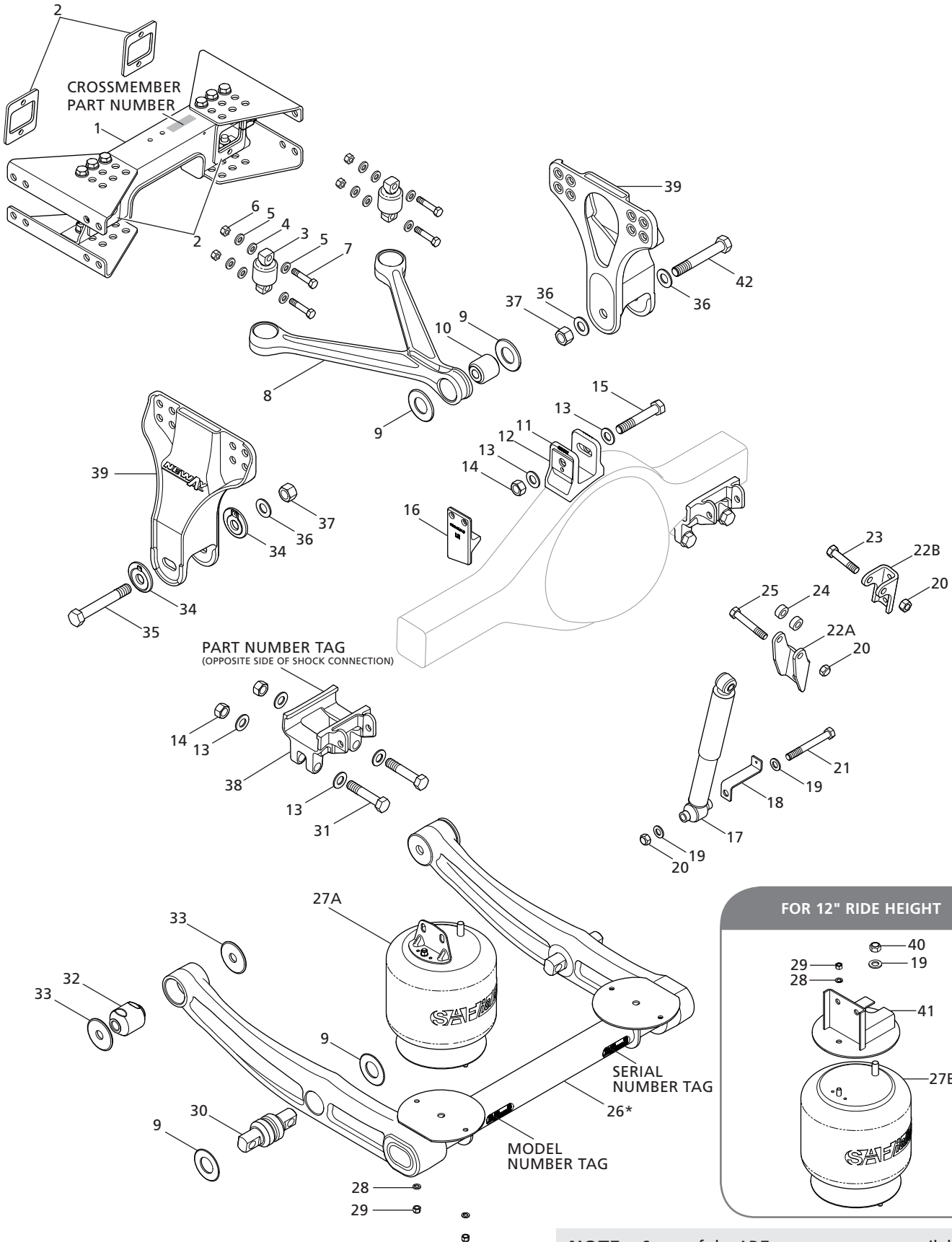

**NOTE:** Some of the ADZ components are available in Service Repair Kits found later in this Section.

**NOTE:** Part quantities listed may reflect usage in several locations.

ITEM	DESCRIPTION	PART NUMBER	QTY.
*1	Frame Crossmember Assembly	Consult SAF-HOLLAND®	1
2	Backer Plate	90034740	4
3	Bar-Pin Bushing, See SRK-645	90008265	2
4	Spacer	Consult SAF-HOLLAND®	4
5	Washer, 0.62" ID	Consult SAF-HOLLAND®	8
6	Lock Nut, 0.62" GRC	Consult SAF-HOLLAND®	4
7	Hex Bolt, 0.62" -11 x 3" GR8	Consult SAF-HOLLAND®	4
8	V-Rod Assembly with Bushings	90549992	1
9	Washer, 4" Dia. Tapered	93600561	6
◆10	Thru Bolt Bushing, Refer to SRK-645	90008264	1
**11	Upper Axle Bracket (V-Rod)	Consult SAF-HOLLAND®	1
†12	Pinion Plate (Replacement Only)		
	0°, 4°, 5°, 9°, 10°, 14°	90034815	2
	1°, 3°, 6°, 8°, 11°, 13°	90034813	2
	2°, 7°, 12°	90034817	2
13	Washer, 1" Inside Dia.	93600168	10
14	Lock Nut, 1" GRC	93400502	5
15	Hex Bolt, 1" -8 x 6" GR8	93004301	1
16	Axle Stop, 10" Ride Height LH Trucks with Drum Brakes	90045616	1
	Axle Stop, 10" Ride Height RH Trucks with Drum Brakes	90045618	1
	Axle Stop, 10" Ride Height LH Trucks with Disc Brakes	90045633	1
	Axle Stop, 10" Ride Height RH Trucks with Disc Brakes	90045635	1
	Axle Stop, 12" Ride Height LH	90045620	1
	Axle Stop, 12" Ride Height RH	90045622	1
17	Shock Absorber	90045605	2
18	HCV Link Bracket	90026410	*
19	Washer, 0.75" ID	93600156	20
20	Lock Nut, 0.75" -10 GR C	93400494	12
21	Hex Bolt, 0.75" -10 x 6.25" GR5	93003663	2
22A	Upper Shock Bracket 10" Ride Height	90018729	2
22B	Upper Shock Bracket 12" Ride Height	90018542	2
23	Hex Bolt, 0.75" -10 x 3.5" GR5	93003597	2
24	Spacer Washer, 10" Ride Height	90036278	4
25	Hex Bolt, 0.75" -10 x 4.75" GR5	93003627	2

**NOTE:** Many of the ADZ components are available in Service Repair Kits found in Section 4.

ITEM	DESCRIPTION	PART NUMBER	QTY.
*26	Lower Control Arm Assembly	Consult SAF-HOLLAND®	1
27A	Air Spring, 10" Ride Height	90557368	2
27B	Air Spring, 12" Ride Height	90557395	2
28	Lock Washer, 0.53" ID	93600072	4
29	Nut, 0.50" -13 GRB	93400136	4
◆◆◆30	Bar-Pin Bushing, Refer to SRK-644	90008267	2
31	Hex Bolt, 1" - 8 x 5" GR8	93004277	4
◆32	Bushing, See SRK-643	90008279	2
33	Washer, 4" Dia. with Chamfer	93600534	4
34	Alignment Puck (Collar)	90001760	2
35	Hex Bolt, 1.12" -7 x 7.75" GR8	93006037	1
36	Washer, 1.12" ID	93600174	2
37	Lock Nut, 1.12" -7 GRC	93400506	2
*38	Lower Axle Adapter Bracket Left and Right Hand**	Consult SAF-HOLLAND®	2
39	Frame Bracket, Fixed 10" Ride Height	90018748	1
	Frame Bracket, Adjustable 10" Ride Height	90018746	1
	Frame Bracket, Fixed 12" Ride Height	90522355	1
	Frame Bracket, Adjustable 12" Ride Height	90522353	1
40	Lock Nut, 0.75" -16 GRB	93400417	2
41	Upper Air Spring Bracket 12" Ride Height	90522289	2
42	Hex Bolt, 1.12" -7 x 7" GR8	93006041	1

\* It is recommended that you discuss your configuration with a SAF-HOLLAND® Product Specialist.

\*\* For Meritor: RT 40 / 41 / 45 - 145

RS 23 - 160

RT 46 - 160

For Dana:

23082T

523 - 170

526 - 190

DT46 - P

D46 - 170

46 - 590 HB (46 - 170)

DSP40 DSH40

† Refer to Pinion Angle Reference Chart in Section 8.

(Some units may not have pinion plates).

◆ NOT for individual sale.

**IMPORTANT:** The part numbers listed may not correspond with the vehicle's ADZ installation. Contact the vehicle OEM for the specific part number information.

# ADZ 126 Series Suspension - Exploded View



SAF-HOLLAND Group

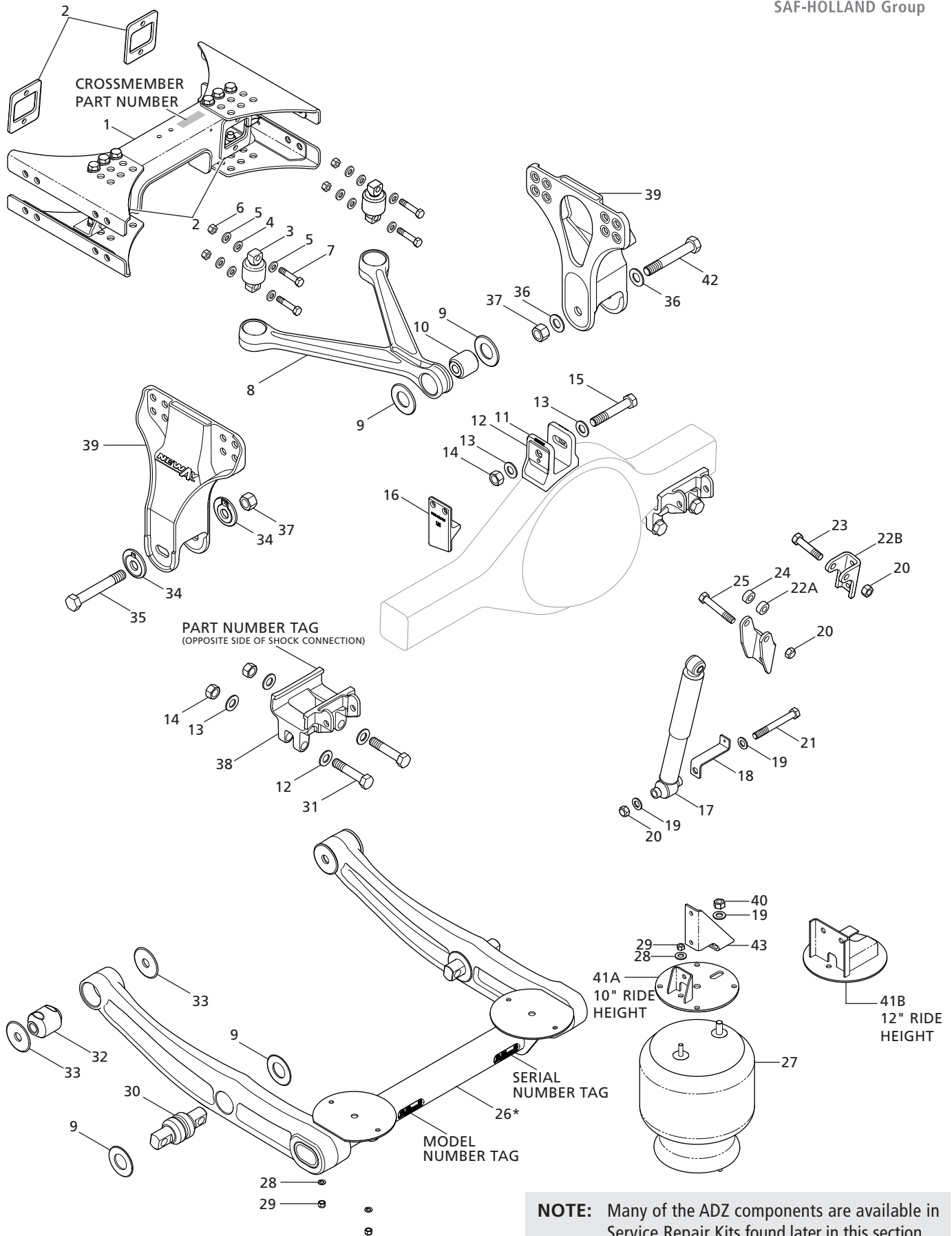



**NOTE:** Part quantities listed may reflect usage in several locations.

ITEM	DESCRIPTION	PART NUMBER	QTY.
*1	Frame Crossmember Assembly	Consult SAF-HOLLAND®	1
2	Backer Plate	90034740	4
◆3	Bar-Pin Bushing, See SRK-645	90008265	2
4	Spacer, 0.62" ID	Consult SAF-HOLLAND®	4
5	Washer, 0.62" ID	Consult SAF-HOLLAND®	8
6	Lock Nut, 0.62" GRC	Consult SAF-HOLLAND®	4
7	Hex Bolt, 0.62"-11 x 3" GR8	Consult SAF-HOLLAND®	4
8	V-Rod Assembly	90549992	1
9	Washer, 4" Dia. Tapered	93600561	6
◆10	Thru Bolt Bushing, Refer to SRK-645	90008264	1
*11	Upper Axle Bracket (V-Rod) **	Consult SAF-HOLLAND®	1
†12	Pinion Plate (Replacement Only) 0°, 4°, 5°, 9°, 10°, 14°	90034815	2
	1°, 3°, 6°, 8°, 11°, 13°	90034813	2
	2°, 7°, 12°	90034817	2
13	Washer, 1" Inside Dia.	93600168	10
14	Lock Nut, 1" GRC	93400502	5
15	Hex Bolt, 1"-8 x 6" GR8	93004301	1
16	Axle Stop, 10" Ride Height LH Trucks with Drum Brakes	90045623	1
	Axle Stop, 10" Ride Height RH Trucks with Drum Brakes	90045625	1
	Axle Stop, 10" Ride Height LH Trucks with Disc Brakes	90045637	1
	Axle Stop, 10" Ride Height RH Trucks with Disc Brakes	90045639	1
	Axle Stop - 12" Ride Height LH	90045627	1
	Axle Stop - 12" Ride Height RH	90045629	1
17	Shock Absorber	90045605	2
18	HCV Link Bracket	90026410	*
19	Washer, 0.75" ID	93600156	20
20	Lock Nut, 0.75"-10 GR C	93400494	12
21	Hex Bolt, 0.75"-10 x 6.25" GR5	93003663	2
*22A	Upper Shock Bracket 10" Ride Height	90018729	2
*22B	Upper Shock Bracket 12" Ride Height	90018542	2
23	Hex Bolt, 0.75"-10 x 3.5" GR5	93003597	2
24	Spacer Washer, 10" Ride Height	90036278	4
25	Hex Bolt, 0.75"-10 x 4.75" GR5	93003627	2
*26	Lower Control Arm Assembly	Consult SAF-HOLLAND®	1

**NOTE:** Many of the ADZ components are available in Service Repair Kits found in Section 4.

ITEM	DESCRIPTION	PART NUMBER	QTY.
27	Air Spring	90557392	2
28	Lock Washer - .53" ID	93600072	4
29	Nut, 0.50"-13 GRB	93400136	4
◆30	Bar-Pin Bushing, Refer to SRK-644	90008267	2
31	Hex Bolt, 1" - 8 x 5" GR8	93004277	4
◆32	Bushing, See SRK-643	90008279	2
33	Washer, 4" Dia. with Chamfer	93600534	4
34	Alignment Puck (Collar)	90001760	2
35	Hex Bolt, 1.12"-7 x 7.75" GR8	93006037	1
36	Washer, 1.12" ID	93600174	2
37	Lock Nut, 1.12"-7 GRC	93400506	2
*38	Lower Axle Adapter Bracket Left and Right Hand**	Consult SAF-HOLLAND®	2
39	Frame Bracket, Fixed 10" Ride Height	90018748	1
	Frame Bracket, Adjustable 10" Ride Height	90018746	1
	Frame Bracket, Fixed 12" Ride Height	90522355	1
	Frame Bracket, Adjustable 12" Ride Height	90522353	1
40	Lock Nut, 0.75"-16 GRB	93400417	2
41A	Upper Air Spring Bracket 10" Ride Height	90531001	2
41B	Upper Air Spring Bracket 12" Ride Height	90522289	2
42	Hex Bolt, 1.12"-7 x 7" GR8	93006041	1
43	Upper Air Spring Bracket	90023131	2

\* It is recommended that you discuss your configuration with a SAF-HOLLAND® Product Specialist.

\*\* For Meritor: RT 40 / 41 / 45 - 145  
RS 23 - 160  
RT 46 - 160

For Dana: 23082T  
523 - 170  
526 - 190  
DT46 - P  
D46 - 170  
46 - 590 HB (46 - 170)  
DSP40 DSH40

† Refer to Pinion Angle Reference Chart in Section 8.  
(Some units may not have pinion plates).

◆ NOT for individual sale.

**IMPORTANT:** The part numbers listed may not correspond with the vehicle's ADZ installation. Contact the vehicle OEM for the specific part number information.

## 4. Service Repair Kits

### Front Pivot Bushing Connection Kit

Part Number: 48100509

SRK-643

ITEM	DESCRIPTION	PART NUMBER	QTY.
32	Bushing	90008279	2
33	Washer, 4" Dia. with Chamfer	93600502	4
*33	Washer, Wear	93600534	4
34	Alignment Puck (Collar)	90001760	2
35	Hex Bolt, 1.12" -7 x 7.75" GR8	93006037	1
36	Washer, 1.12" ID	93600174	3
37	Lock Nut, 1.12"-7 GRC	93400506	2
42	Hex Bolt, 1.12" - 7 x 7" GR8	93006041	1

\* Some units may have the frame brackets with a wider clevis opening.

- Cast brackets marked 90018737 or (90018739)

- Fabricate brackets marked 90522271 or (90522272)

Use both 93600502 and 93600534 to fill up clevis space.

SRK-643

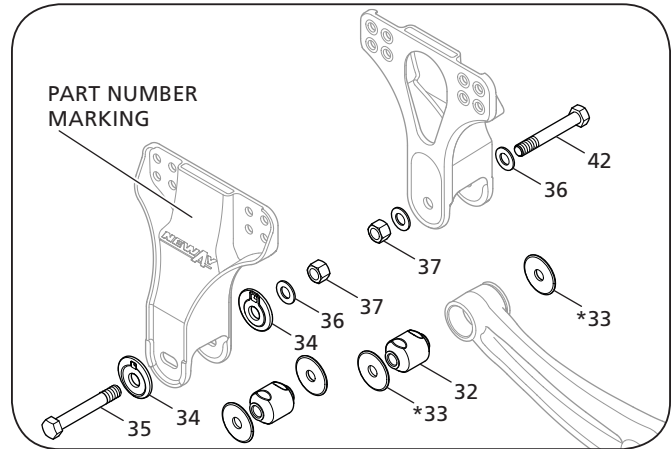

### Axle Bar-Pin Bushing Connection Kit

Part Number: 48100510

SRK-644

ITEM	DESCRIPTION	PART NUMBER	QTY.
30	Bar-Pin Bushing	90008267	2
9	Washer, 4" Dia. with Chamfer	93600561	4
13	Washer, 1" Inside Dia.	93600168	8
14	Lock Nut, 1" GRC	93400502	4
31	Hex Bolt, 1" - 8 x 5" GR8	93004277	4

SRK-644

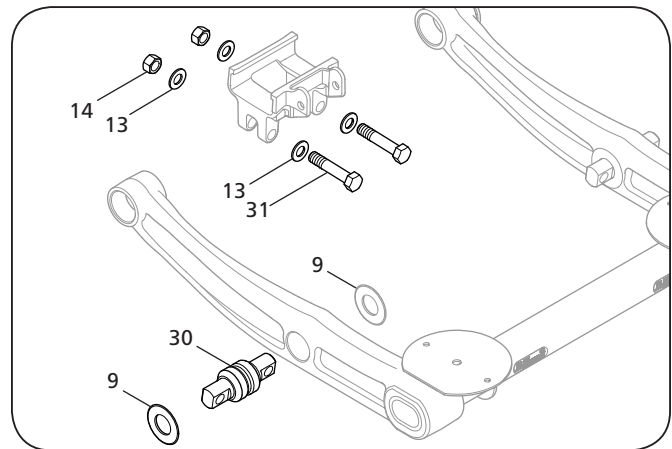

## Pinion Plate Hardware Kit

**Part Number: 48100549**
**SRK-683**

ITEM	DESCRIPTION	PART NUMBER	QTY.
9	Washer, Spacer	93600561	2
†12	Pinion Plate	Refer to Note Below	2
13	Washer, 1" Inside Dia.	93600168	2
14	Lock Nut, 1" GRC	93400502	1
15	Hex Bolt, 1"-8 x 6" GR8	93004301	1

† Three (3) Sets of Pinion Plates included in kit. Use the correct part number based on the pinion angle of the axle. Part numbers 90034815 and 90034813 may be flipped over to achieve pinion angle setting (discard all unused pinion plates).

Part Number: 90034815 - 0°, 4°, 5°, 9°, 10°, 14°

Part Number: 90034813 - 1°, 3°, 6°, 8°, 11°, 13°

Part Number: 90034817 - 2°, 7°, 12°

Quantity two (2) per axle.

For proper component, refer to Pinion Angle Reference Chart in Section 8.

### SRK-683

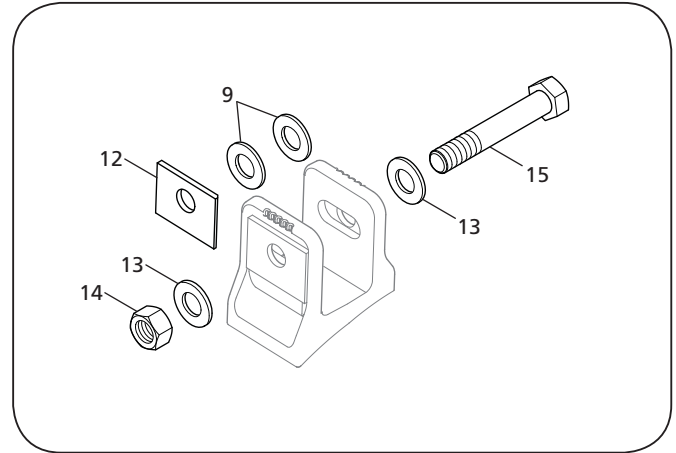

## V-Rod Bushing Connection Kit

**Part Number: 48100511**
**SRK-645**

ITEM	DESCRIPTION	PART NUMBER	QTY.
3	Bar-Pin Bushing	90008265	2
4	Spacer, 0.62" ID	Consult SAF-HOLLAND®	4
5	Washer, 0.62" ID	Consult SAF-HOLLAND®	8
6	Lock Nut, 0.62" GRC	Consult SAF-HOLLAND®	4
7	Hex Bolt, 0.62"-11 x 3" GR8	Consult SAF-HOLLAND®	4
10	Thru Bolt Bushing	90008264	1

**THE FOLLOWING PARTS ARE ALSO INCLUDED IN KIT SRK-683**

9	Washer, 4" Dia. with Chamfer	93600561	2
12†	Pinion Plate	Refer to Note Below	2
13	Washer, 1" Inside Dia.	93600168	2
14	Lock Nut, 1" GRC	93400502	1
15	Hex Bolt, 1"-8 x 6" GR8	93004301	1

### SRK-465

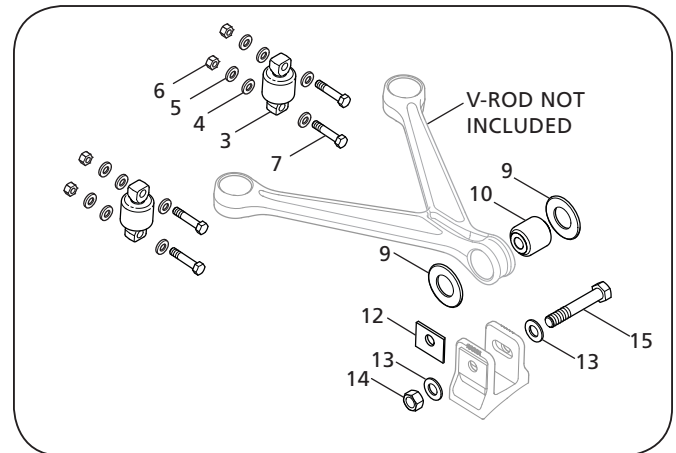

**NOTE:** SAF-HOLLAND® offers a standard pinion plate system for retrofit/aftermarket replacement.

† Three (3) Sets of Pinion Plates included in kit. Use the correct part number based on the pinion angle of the axle. Part numbers 90034815 and 90034813 may be flipped over to achieve pinion angle setting.

Part Number: 90034815 - 0°, 4°, 5°, 9°, 10°, 14°

Part Number: 90034813 - 1°, 3°, 6°, 8°, 11°, 13°

Part Number: 90034817 - 2°, 7°, 12°

Quantity two (2) per axle.

For proper component, refer to Pinion Angle Reference Chart in Section 8.

## 5. Pre-Operation

1. With the vehicle on a level surface, build air pressure above 70 psig (4.83 bars).
2. Shut off the vehicle and visually check all air control system fittings for air leaks by applying a soapy water solution and checking for bubbles at all air connections and fittings. Check the air springs for equal firmness.
3. With the vehicle loaded at design capacity, check that there is a 1.5" (38 mm) minimum clearance around the air springs, 2.5" (64 mm) when unloaded (**Figure 4**).

**NOTE:** At certain axle pinion angles the distance from the spring to the shock absorber will be less than 1.5" (38 mm) and is permissible.

4. Verify that the upper and lower air spring hardware (**Figure 4**) are torqued according to the specifications listed in Section 16 and/or OEM specifications.

**NOTE:** When re-torquing, the nut should be loosened a couple of turns and then torqued to the recommended specification.

5. Check the shock absorbers for proper installation and that the .75" upper and lower shock absorber hardware (**Figure 4**) are torqued according to the specifications listed in Section 16.
6. Check that the 1.13" (29 mm) pivot connection bolt (**Figure 5**) is torqued according to the specifications listed in Section 16.

**NOTE:** All pivot connection bolts supplied by SAF-HOLLAND® have a pre-applied coating (silver in color) which provides thread lubrication throughout the expected service life of the bolts.

7. Check for proper installation of spacer washers at the pivot connection and at the axle connection (**Figure 5**).
8. Verify that the axle adapter connection hardware (**Figure 5**) are torqued according to the specifications listed in Section 16.

**NOTE:** Different frame widths require various spacer washer placements at the pivot connection. Refer to Section 11 (**Figure 31**) for further information.

9. Verify that all frame fasteners (**Figure 6**) are torqued according to the chassis builder OEM's recommended torque specifications.

**NOTE:** Hardware attaching components to the vehicle frame are typically the responsibility of the vehicle OEM. Refer to OEM for torque, grade and size.

**Figure 4**

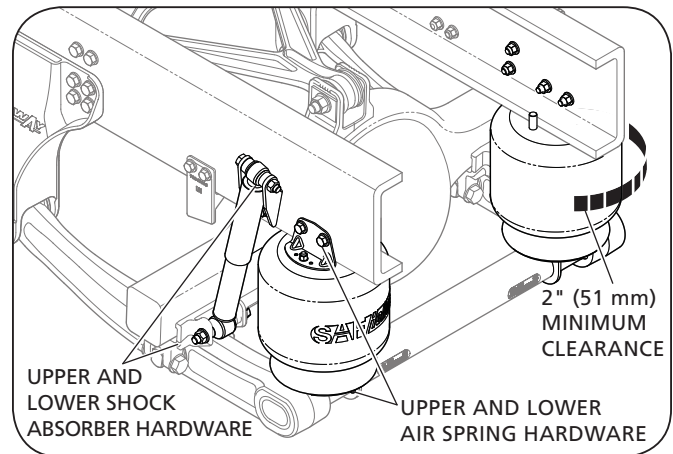

**Figure 5**

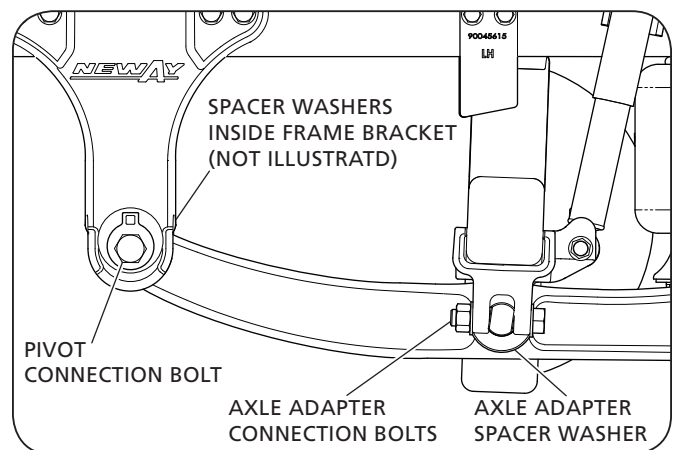

**Figure 6**

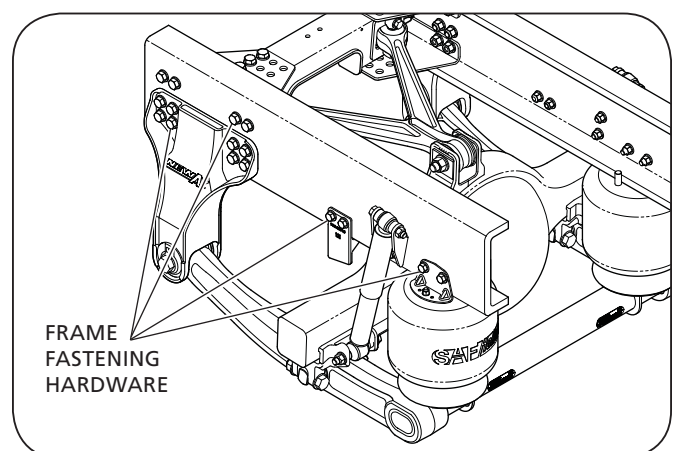

10. The suspension ride height should be within  $\pm .25$ " (6 mm) of the recommended design height. Refer to Section 6 for further ride height information.
11. Weld-On Axle Adapter Bracket (**Figure 7**): The welds connecting the axle adapter brackets to the axle MUST be to the axle manufacturer's or vehicle OEM's specifications.
12. Check that the axle pinion angle (axle tilt) is within the chassis builder's specifications. Refer to (**Figure 8**) for definition of the pinion angle.
13. Ensure that SAF-HOLLAND<sup>®</sup> axle stops are properly installed (**Figure 9**).

**CAUTION**

Failure to properly install the axle stops could result in component failure which, if not avoided, could result in minor or moderate injury.

14. Check the alignment of the suspension per vehicle OEM instructions. If realignment is necessary, refer to the alignment procedures described in Section 6.

**Figure 7**

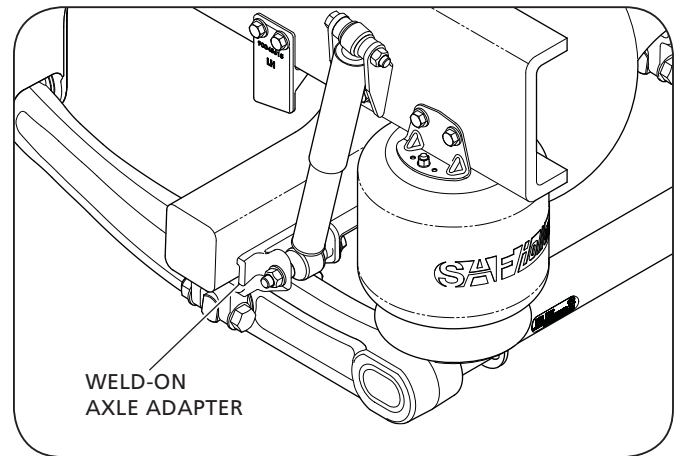

**Figure 8**

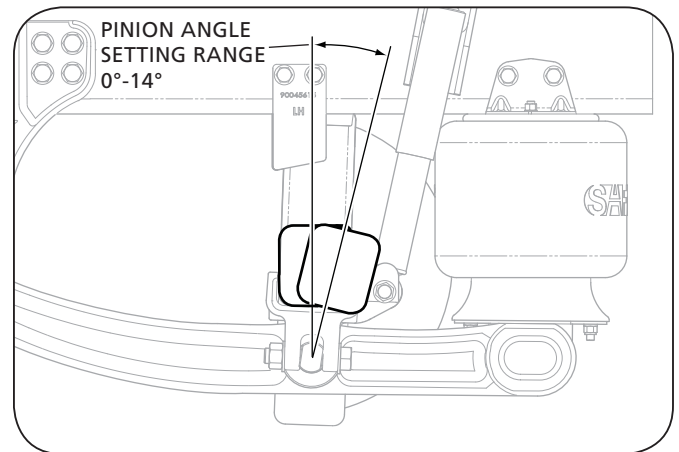

**Figure 9**

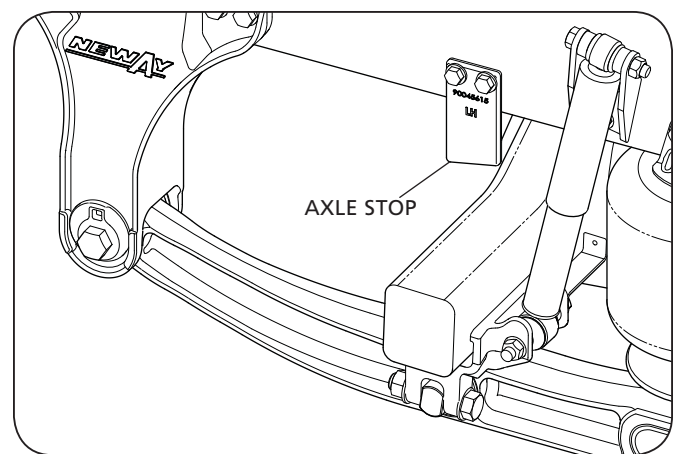

## 6. Ride Height Adjustment

Proper suspension ride height should be within  $\pm .25$ " (6 mm) of the specified ride height.

**NOTE:** The specified ride height can be found in the model number (Example: Model ADZ-123-10, the ride height is 10").

To check the current ride height of the suspension, use the following steps:

1. Drive the vehicle forward in a straight line for at least two (2) vehicle lengths to release any bushing wind up.
2. With the vehicle unloaded and/or trailer disconnected on a level surface, chock the front tires to prevent the vehicle from rolling forward or backward.
3. Pressurize the air system with a constant supply of air in excess of 70 psig (4.8 bars) and check that all air springs properly inflate and raise the suspension to the proper ride height.
4. Measure the distance from the bottom of the frame rail to the ground (**Figure 10 - Arrow A**).
5. Measure the distance from the center of the wheel to the ground (**Figure 10 - Arrow B**).
6. Subtract the measurement found in Step 5 from the measurement found in Step 4 to determine the current ride height of the suspension.

Example: The bottom of the frame rail to the ground measures 30" (762 mm) "A".  
The center of the wheel to the ground measures 20" (508 mm) "B".

$A$  (30") minus  $B$  (20") = Ride Height (10.0")

Current suspension ride height = 10.0"

**IMPORTANT:** If the measured ride height is NOT within  $\pm .25$ " (6 mm) it MUST be adjusted using the height control valve. Refer to the height control valve manufacturer's instructions for adjustment procedures.

**NOTE:** If proper ride height is NOT obtained or air springs DO NOT inflate properly; check the air pressure and check for proper piping in accordance with the truck manufacturer's procedures and owner's manual then repeat the above steps. If the proper ride height still cannot be obtained, contact the vehicle's OEM for assistance.

Figure 10

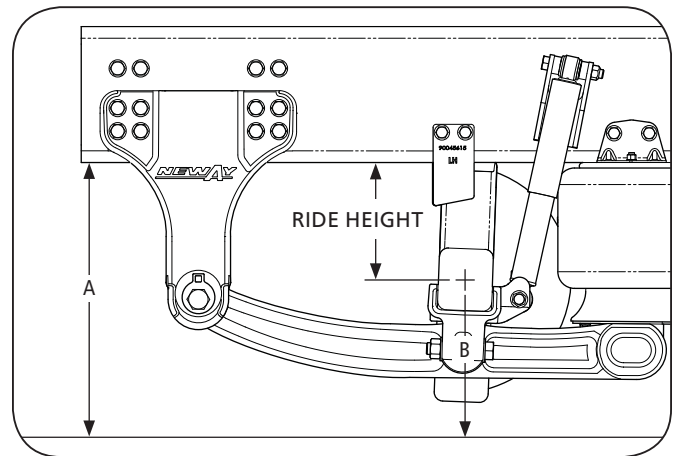

## 7. Axle/Suspension Alignment

**IMPORTANT:** The vehicle **MUST** be set to the proper Ride Height before performing axle alignment procedure. Refer to Section 6 for more information.

**IMPORTANT:** When performing axle alignment, the procedure must be performed on all drive axles equipped with Neway® ADZ suspensions.

**NOTE:** The Neway® ADZ suspension is typically installed by the OEM/chassis builder with one "adjustable" frame bracket (typically roadside) and one "fixed" frame bracket (typically curbside). The adjustable frame bracket can be visually identified by an alignment collar located behind the head of the pivot connection bolt (**Figure 11**). There is a .5" (13 mm) square hole in the alignment collar above the bolt head, which is used to align the axles.

**NOTE:** These instructions assume that the suspension was properly installed and adjusted by the vehicle OEM/Chassis builder.

1. With the vehicle unloaded and/or trailer disconnected on a level surface, chock the front tires to prevent the vehicle from rolling forward or backward.
2. Support the frame with jack stands (**Figure 12**) and exhaust all air from the system by disconnecting the link from the lower connection of the height control valve and pulling down on the link (**Figure 13**). Refer to the height control valve manufacturer's instructions for further information.

**⚠ WARNING** Failure to properly support the vehicle prior to commencing work could create a crush hazard which, if not avoided, could result in death or serious injury.

3. Loosen the pivot connection bolt nut on the adjustable frame bracket (**Figure 11**). **DO NOT** remove the bolt and nut from the frame bracket.

**⚠ WARNING** Removing the pivot bolt from the frame bracket will cause the suspension to fall which, if not avoided, could result in death or serious injury.

**Figure 11**

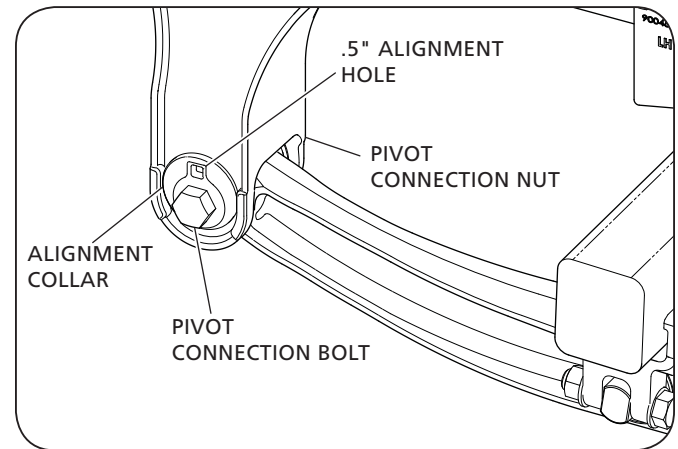

**Figure 12**

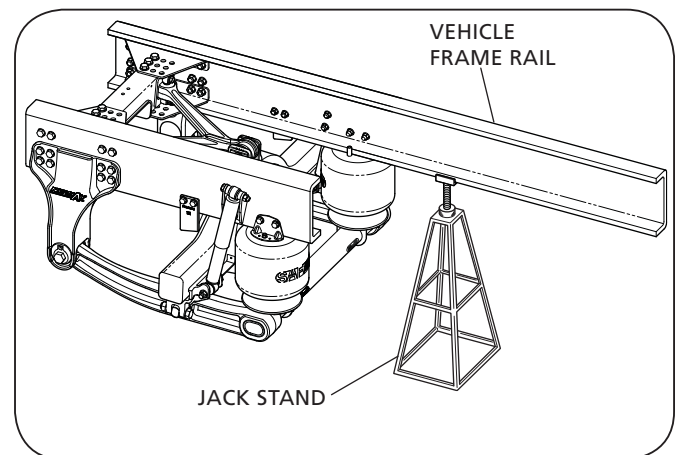

**Figure 13**

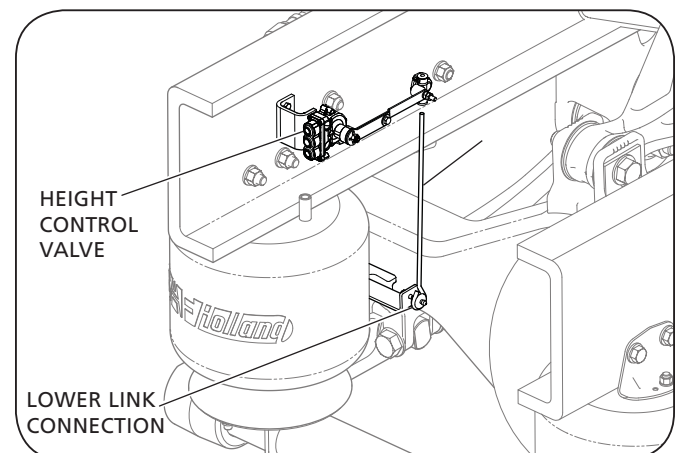

- Using two (2) .5" (13 mm) drive ratchet wrenches (one on each side of frame bracket, inside and out), adjust the axle alignment by placing the ratchet wrenches into the .5" square hole of the alignment collars and turning counter-clockwise simultaneously to move the axle rearward (**Figure 14, Arrow A**), and clockwise to move the axle forward (**Figure 14, Arrow B**).

**NOTE:** There is .5" (13 mm) of total allowable axle adjustment: .25" (6 mm) forward and .25" (6 mm) rearward.

- When the axle has been properly aligned per vehicle OEM specifications, torque the nut on the pivot connection bolt (**Figure 15**) according to the specifications listed in Section 16.

**NOTE:** Drive torque may cause alignment collars to rotate. Use .5" drive ratchet wrench to resist rotation while tightening the pivot bolt.

- Verify that the pivot connection bolt on the fixed frame bracket is torqued according to the specifications listed in Section 16.
- Reconnect the air supply line to the air springs.
- Raise the rear of the vehicle using the vehicle's lift points and remove the jack stands. Refer to the procedures provided by the vehicle OEM.
- Increase the suspension air system reservoir pressure in excess of 70 psig (4.83 bars) and check for leaks. All air springs should inflate and raise the suspension to the proper ride height.

## 8. Replacing Pinion Plates

The Neway® ADZ Series Suspension design allows for axle pinion angle setting range of 0° through 14° in 1° increments (**Figure 16**). All fifteen (15) axle pinion angle settings can be achieved through a combination of adjusting the crossmember (**Figure 17**) forward or rearward and by the selection of the proper upper axle bracket by the vehicle OEM with the pinion angle plates (**Figure 17**) located on the V-Rod axle adapter connection.

**IMPORTANT:** Before changing and/or replacing the vehicle pinion angle, consult the vehicle OEM for approved pinion angle settings and weld specifications.

### **WARNING**

Failure to use the correct pinion angle setting and application can cause drive-line component failure which, if not avoided, could result in death or serious injury.

**IMPORTANT:** Adjusting the pinion angle will change the vehicle ride height. After the pinion angle adjustment check the ride height and make sure it is within  $\pm .25"$  (6 mm) of OEM specification; adjust the ride height as necessary. Refer to Section 6 for ride height adjustment information.

**Figure 14**

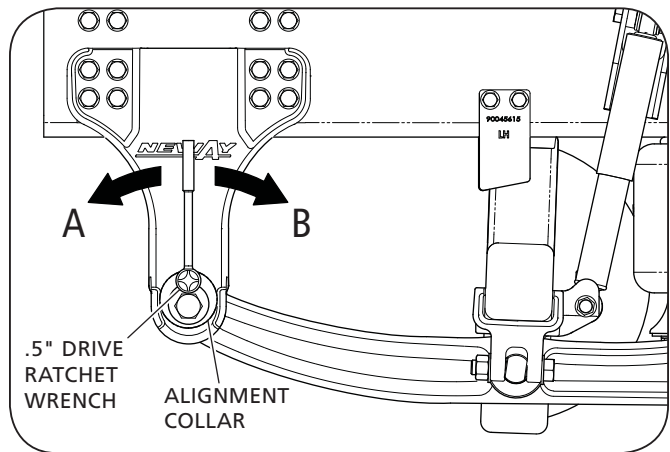

**Figure 15**

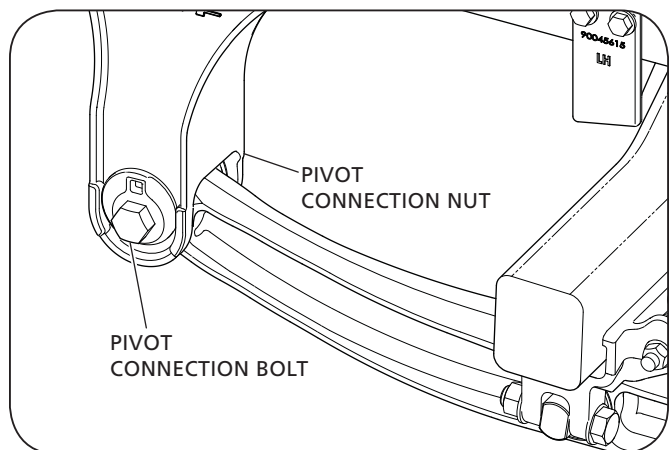

**Figure 16**

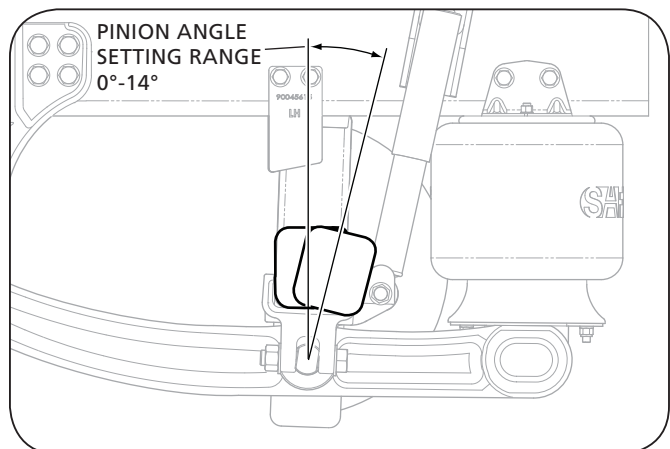



**IMPORTANT:** Adjusting the pinion angle may require a different pinion plate. Refer to the service repair kits in Section 4.

**NOTE:** If crossmember repositioning is necessary, adjust the pinion angle plate position first then proceed to crossmember positioning.

### 8.1 V-Rod Pinion Plate Replacement

1. With the vehicle unloaded and/or trailer disconnected on a level surface, chock the front tires to prevent the vehicle from rolling forward or backward.
2. Support the frame with jack stands (**Figure 12**).

**WARNING** Failure to properly support the vehicle prior to commencing work could create a crush hazard which, if not avoided, could result in death or serious injury.

3. Using a floor jack support the axle at the axle bowl and block the axle to prevent it from rotating when the bolts are removed from the frame crossmember assembly.

**WARNING** Failure to properly support the vehicle prior to commencing work could create a crush hazard which, if not avoided, could result in death or serious injury.

4. Exhaust all air from the system by disconnecting the link from the lower connection of the height control valve and pulling down on the link (**Figure 18**). Refer to the height control valve manufacturer's instructions for further information.
5. Remove the rear V-Rod attachment bolt from the upper axle bracket (**Figure 19**). Make sure the two (2) spacer washers that are between the inside faces of the upper axle bracket and the V-Rod do not fall out.
6. Remove the two (2) pinion plates from each side of the axle bracket (**Figure 19**). These may be tack welded in place. They may require grinding out the tack weld to remove.

**IMPORTANT:** Exercise care when grinding off welds. Grind weld material flush to the base material. DO NOT damage the upper axle bracket material. Rear V-Rod attachment bolt will hold the plate in place making it unnecessary to re-weld new plates.

7. Determine the correct pinion angle from the OEM for the axle being serviced and obtain the correct pinion plates for desired pinion angle. Refer to Section 4 table notes under SRK-683 and SRK-645 for correct pinion plate part numbers.

**Figure 17**

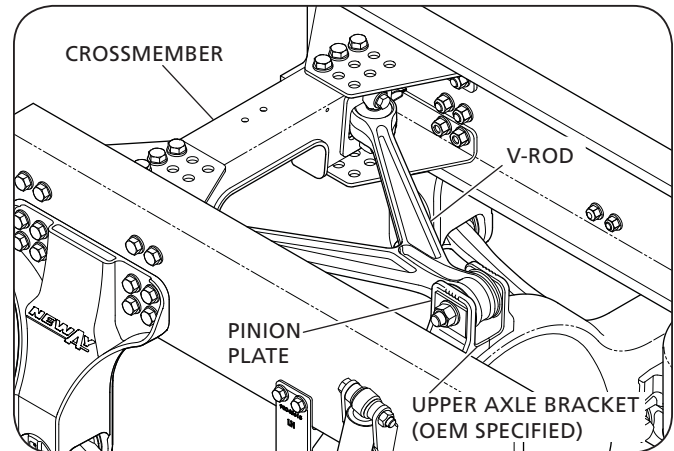

**Figure 18**

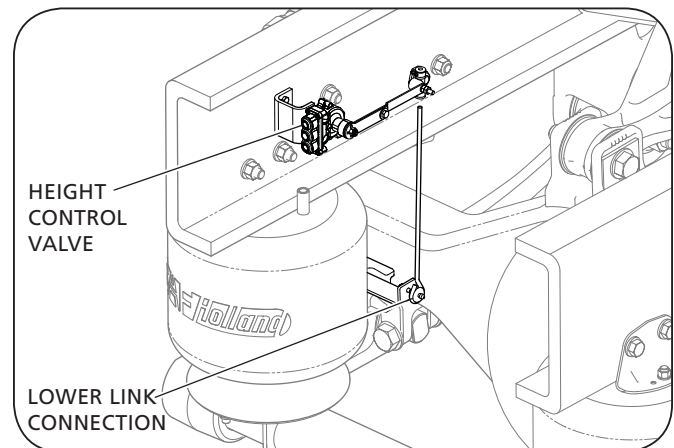

**Figure 19**

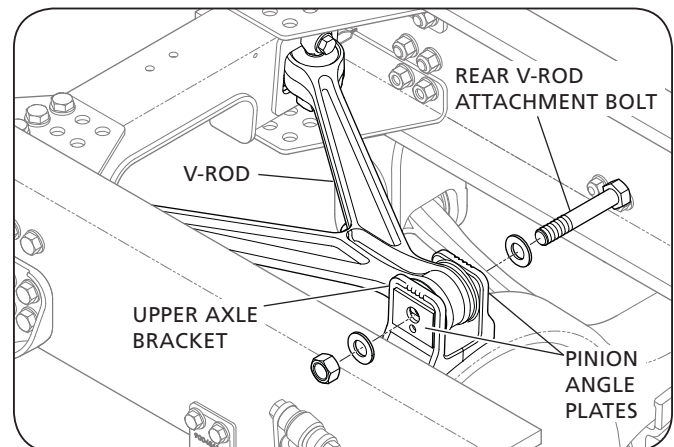

8. Re-position the new pinion plates on the upper axle bracket according to the position determined in Step 7.
9. Re-install the rear V-Rod attachment bolt (making sure the spacer washers are in place) and re-torque the bolt to the torque specification listed in Section 16. New hardware is recommended to achieve proper fastener clamp load. Refer to SRK-683 in Section 4.
10. Increase the suspension air system reservoir pressure in excess of 70 psig (4.83 bars) and check for leaks. All air springs should inflate and raise the suspension to the proper ride height.
11. If designated pinion angle has been achieved, remove the floor jack from under the axle bowl and blocking from the axle.

## 8.2 Crossmember Positioning (if required)

1. With the vehicle unloaded and/or trailer disconnected on a level surface, chock the front tires to prevent the vehicle from rolling forward or backward.
2. Support the frame with the jack stands (**Figure 20**).

**⚠ WARNING** Failure to properly support the vehicle prior to commencing work could create a crush hazard which, if not avoided, could result in death or serious injury.

3. Using a floor jack, support the axle at the axle bowl and block the axle to prevent it from rotating when the bolts are removed from the frame crossmember assembly.

**⚠ WARNING** Failure to properly support the vehicle prior to commencing work could create a crush hazard which, if not avoided, could result in death or serious injury.

4. Exhaust all air from the system by disconnecting the link from the lower connection of the height control valve and pulling down on the link (**Figure 21**). Refer to the height control valve manufacturer's instructions for further information.
5. Remove the crossmember fastening hardware that attach the center section of the frame crossmember to the four (4) wing plates (**Figure 22**).
6. Refer to the Pinion Angle Reference Chart later in this Section to determine the appropriate crossmember position one, two or three (1,2 or 3) to achieve the desired pinion angle.
7. Re-position the center section of the crossmember forward or rearward to position one, two or three 1, 2 or 3 on the wing plate depending on the position determined in Step 4.
8. Re-assemble the crossmember fastening hardware (**Figure 22**) and re-torque to the specification listed in Section 16.
9. If the designated pinion angle has been achieved, remove the block and floor jack from the axle.

**Figure 20**

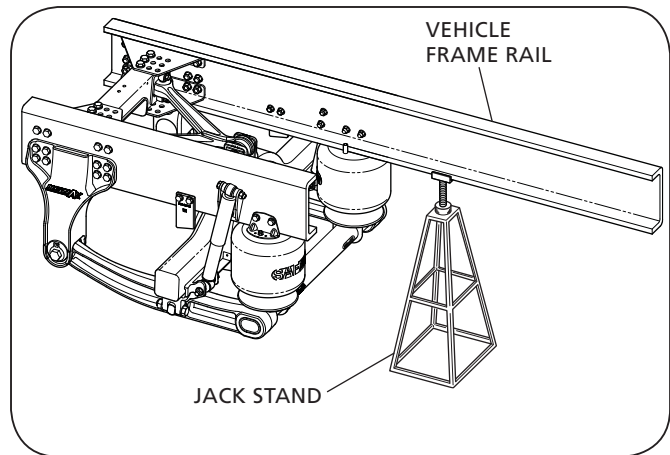

**Figure 21**

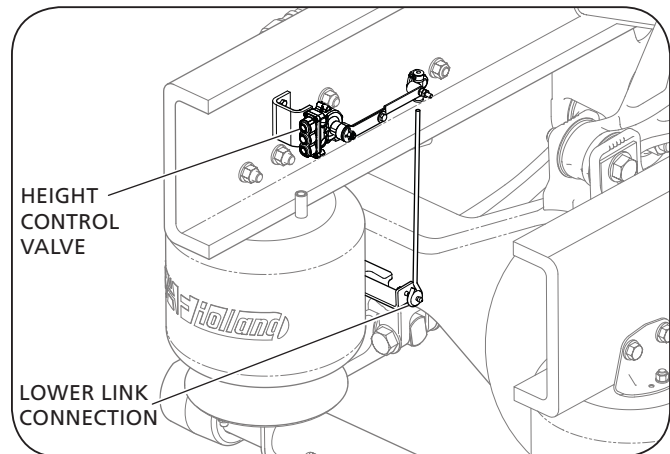

**Figure 22**

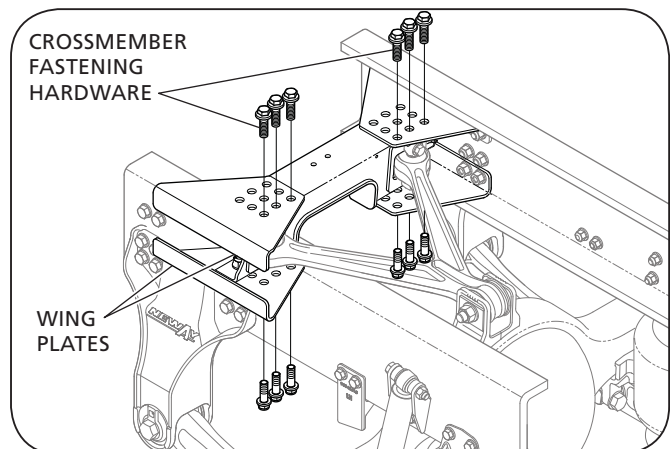

PINION ANGLE SETTINGS FOR 0°, 5° AND 10° PART NUMBER 90034815			
PINION PLATE ORIENTATION	0° ANGLE CROSSMEMBER IN POSITION 1	5° ANGLE CROSSMEMBER IN POSITION 2	10° ANGLE CROSSMEMBER IN POSITION 3
PINION ANGLE SETTINGS 1°, 6° AND 11° PART NUMBER 90034813			
PINION PLATE ORIENTATION	1° ANGLE CROSSMEMBER IN POSITION 1	6° ANGLE CROSSMEMBER IN POSITION 2	11° ANGLE CROSSMEMBER IN POSITION 3
PINION ANGLE SETTINGS 2°, 7° AND 12° PART NUMBER 90034817			
PINION PLATE ORIENTATION	2° ANGLE CROSSMEMBER IN POSITION 1	7° ANGLE CROSSMEMBER IN POSITION 2	12° ANGLE CROSSMEMBER IN POSITION 3
PINION ANGLE SETTINGS 3°, 8° AND 13° PART NUMBER 90034813			
PINION PLATE ORIENTATION	3° ANGLE CROSSMEMBER IN POSITION 1	8° ANGLE CROSSMEMBER IN POSITION 2	13° ANGLE CROSSMEMBER IN POSITION 3
PINION ANGLE SETTINGS 4°, 9° AND 14° PART NUMBER 90034815			
PINION PLATE ORIENTATION	4° ANGLE CROSSMEMBER IN POSITION 1	9° ANGLE CROSSMEMBER IN POSITION 2	14° ANGLE CROSSMEMBER IN POSITION 3

**NOTE:** Pinion angle settings as illustrated are for front engine pinion angle adjustments. For a rearward axle tilt, rear engine pinion angle adjustments are opposite of illustrated. Example: 0°, 15°, 10° use 4°, 9°, 14° instead.

## 9. Air Spring Replacement

**IMPORTANT:** Air springs **MUST** be replaced with the proper air spring for vehicle installation. Replacement air springs are available through SAF-HOLLAND® Original Parts. Check the flexible member and piston for the part number. If the part number is unidentifiable, contact the vehicle OEM for assistance or SAF-HOLLAND® Technical Service at 888-396-6501.

1. With the vehicle unloaded and/or trailer disconnected on a level surface, chock the front tires to prevent the vehicle from rolling forward or backward.
2. Support the vehicle frame with the jack stands (**Figure 23**).

**WARNING** Failure to properly support the suspension during servicing could allow the suspension to fall which, if not avoided, could result in death or serious injury.

3. Using a floor jack support the axle at the axle bowl (**Figure 23**).
4. Exhaust all air from the system by disconnecting the link from the lower connection of the height control valve and pulling down on the link (**Figure 24**). Refer to the height control valve manufacturer's instructions for further information.
5. Disconnect the air supply line from the air spring.

**NOTE:** If the air spring has a leak and is deflated, Step 4 must still be performed.

6. Remove the frame rail and lower air spring mounting plate fastening hardware and remove the old air spring assembly (**Figure 25**).

**NOTE:** ADZ-123-12 and all ADZ-126 Series have an upper air spring mounting plate bracket and frame gusset (inside frame). Removal of the air spring vertical mount nuts is also required to remove the old air spring assembly (**Figure 25**).

7. Install the new air spring assembly to the frame rails and lower the air spring mounting plate and torque the lower air spring mounting plate fastening hardware according to the specifications listed in Section 16.
8. Torque the frame rail fastening hardware per the OEM recommended torque specifications.
9. Re-connect the air supply line and height control valve lower-link connection.
10. Raise the rear of the vehicle using the vehicle's lift points to remove the jack stands under the vehicle frame. Refer to the procedures provided by the vehicle OEM.
11. Increase the suspension air system reservoir pressure in excess of 70 psig (4.83 bars) and check for leaks. All air springs should inflate and raise the suspension to the proper ride height.
12. Check the ride height and make sure it is within  $\pm .25$ " (6 mm) of specification and adjust as necessary. Refer to Section 6 for ride height adjustment information.
13. Check the alignment of the suspension per vehicle OEM instructions. If realignment is necessary, refer to the alignment procedures described in Section 7.

Figure 23

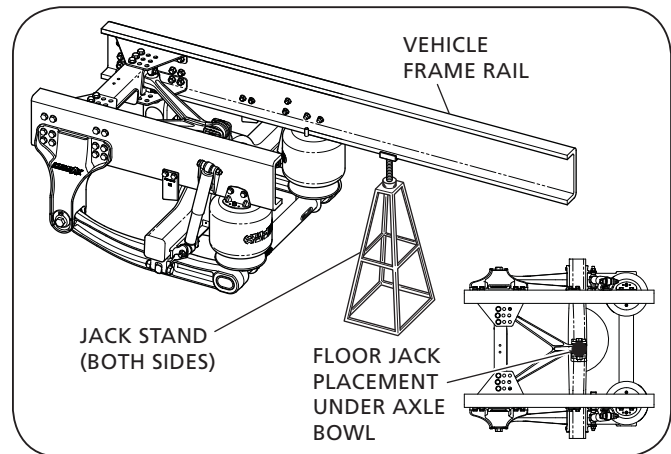

Figure 24

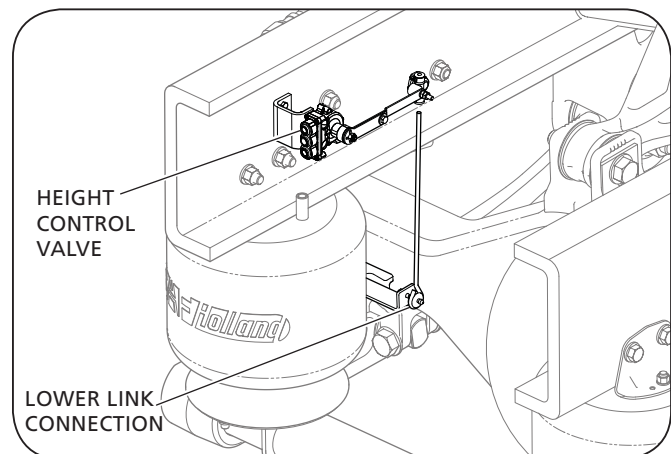
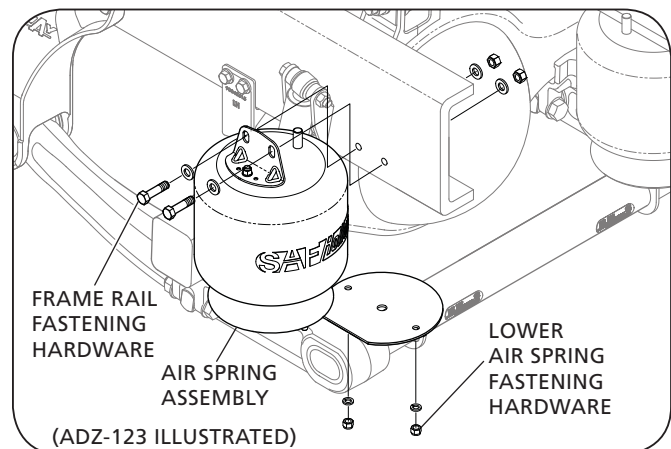

Figure 25



## 10. Shock Absorber Replacement

**NOTE:** It is important to note that it is a normal condition for an oil mist to cover the shock absorber and may not be cause for replacement.

**NOTE:** To verify that a shock absorber is working properly, drive the vehicle at a moderate speed for approximately 10 minutes. Return and check if the shock absorber is above ambient temperature by using any type of non-contact thermal measuring device and pointing it at lower portion of shock absorber (NOT upper dust shield). If the shock is above ambient temperature it is working properly and DOES NOT require replacement.

**CAUTION** Physical contact with hot shock absorbers could result in minor or moderate burns.

**IMPORTANT:** Shock absorbers MUST be replaced with the proper shock absorbers for vehicle installation. Replacement shock absorbers are available through SAF-HOLLAND® Original Parts. Check the side of shock absorber for the part number. If the part number is unidentifiable, contact vehicle OEM or SAF-HOLLAND® Technical Service at 888-396-6501.

1. With the vehicle unloaded and/or trailer disconnected on a level surface, chock the front tires to prevent the vehicle from rolling forward or backward.
2. Raise the rear of vehicle using vehicle's lift points. Refer to the procedures provided by vehicle OEM.
3. Support the vehicle frame using jack stands and remove the tires (**Figure 26**).

**WARNING** Failure to properly support the vehicle during maintenance could allow the vehicle to fall which, if not avoided, could result in death or serious injury.

4. Using a floor jack support the axle at the axle bowl (**Figure 26**).
5. Remove the upper and lower shock absorber connection fastening hardware and remove the old shock absorbers (**Figure 27**).
6. Install the new shock absorbers and spacers, when applicable, to the upper and lower shock absorber connections and torque the upper and lower connection fastening hardware according to the specifications listed in Section 16 (**Figure 27**).
7. Re-install the tires and any remaining components and torque the tire hardware to the wheel manufacturer's specifications.
8. Lower the vehicle and remove the floor jack.
9. Check ride height and make sure it is within  $\pm .25$ " (6 mm) of specification and adjust as necessary. Refer to Section 6 for ride height adjustment information.

Figure 26

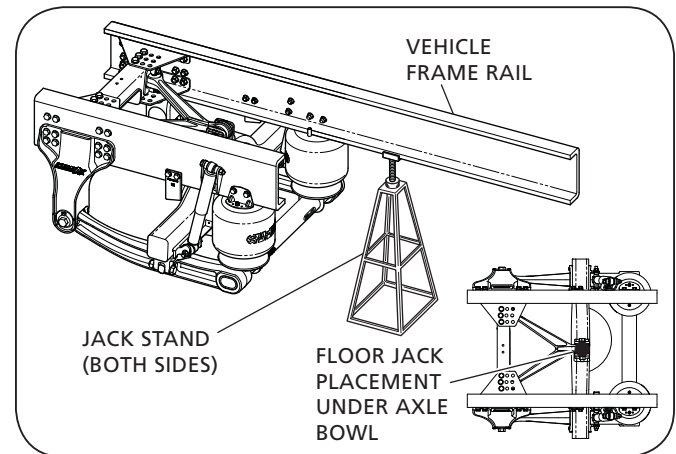
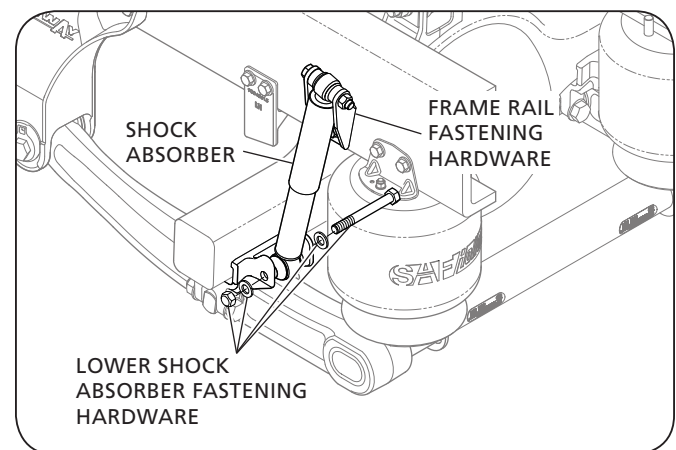
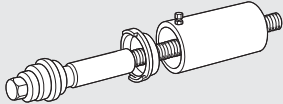

Figure 27



## 11. Axle Adapter Bar-Pin Bushing and Pivot Connection Bushing Replacement

**NOTE:** The SAF-HOLLAND® Bushing Service Tool, Part No. 50544012, is available to ease the removal and replacement of the pivot bushings. Contact SAF-HOLLAND® Customer Service for ordering information.



1. With the vehicle unloaded and/or trailer disconnected on a level surface, chock the front tires to prevent the vehicle from rolling forward or backward.
2. Raise the rear of the vehicle using the vehicle's lift points. Refer to the procedures provided by the vehicle OEM.
3. Support the vehicle frame using the jack stands and remove the tires (**Figure 28**).
4. Using the floor jacks; support the axle at the axle bowl and the lower control arm assembly at the transverse beam (**Figure 28**).

**IMPORTANT:** Be careful NOT to gouge or mark the transverse beam with the floor jack.

**⚠ WARNING** Gouging or marking the transverse beam could cause component failure and loss of vehicle control which, if not avoided, could result in death or serious injury.

5. Using two (2) floor jacks, support both sides of the lower control arm assembly near the pivot connection (**Figure 28**).

**⚠ WARNING** Failure to properly support the suspension during maintenance could allow the suspension to fall which, if not avoided, could result in death or serious injury.

6. Exhaust all air from the system by disconnecting the link from the lower connection of the height control valve and pulling down on the link (**Figure 29**). Refer to the height control valve manufacturer's instructions for further information.

7. Disconnect the air supply line from the air spring.

**NOTE:** If the air spring has a leak and is deflated, Step 7 MUST still be performed.

8. Disassemble the shock absorbers and air springs at their lower connections only (**Figure 30**).

Figure 28

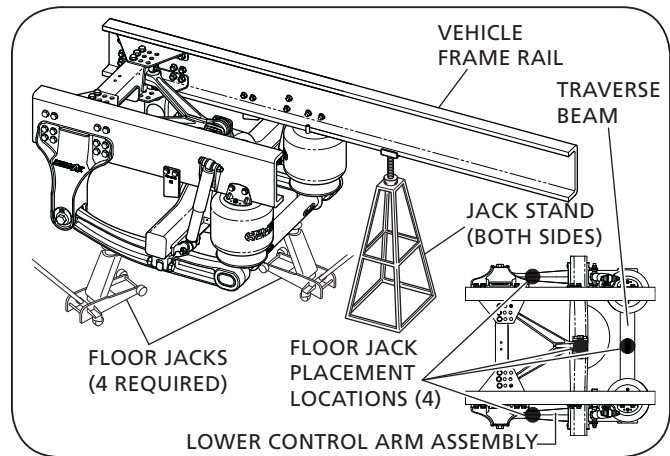

Figure 29

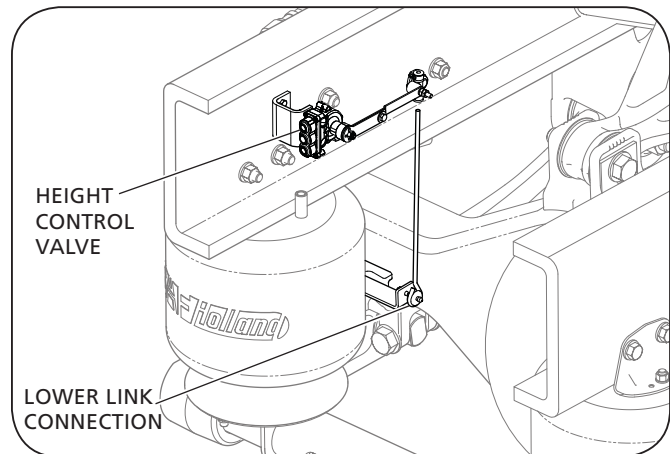
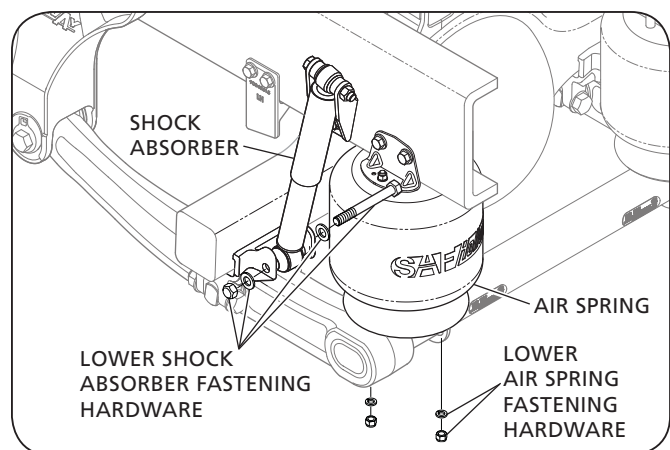

Figure 30



- Remove and discard the fastening hardware connecting the axle adapter bracket to the bar-pin bushing and the pivot connection (on both sides) (**Figure 31**). Refer to Section 4 for Service Repair Kits for pivot and axle connections.

**NOTE:** Be sure to note the current assembled position of the spacer washers in the pivot connection as this will be needed for re-assembly (**Figure 32**).

- Using a paint pen, draw a line to mark the pinion angle of the bar-pin bushing as this will be needed for installation of the new bushings (**Figure 33**).
- Using a floor jack, lower the lower control arm assembly down from the frame brackets and axle adapters to access the bushings.
- Properly support and secure the lower control arm assembly to remove the bushings.

**CAUTION** Failure to properly support the lower control arm assembly could allow the lower control arm assembly to shift abruptly when removing bushings which, if not avoided, could result in minor or moderate injury.

- Press out the old bushings using a fifteen (15) ton or larger hydraulic press or the SAF-HOLLAND® Bushing Service Tool.
- Clean out all foreign material from the bushing receptacles in the lower control arm assembly.

**NOTE:** DO NOT use any open flame or other heat source to remove the bushings.

- Visually inspect all components for wear, cracks or failed welds and replace as necessary.

**WARNING** Failure to replace components that are worn, cracked or have failed welds could cause component failure and loss of vehicle control which, if not avoided, could result in death or serious injury.

**IMPORTANT:** NEVER weld to the transverse beam of the lower control arm assembly. If anything has been welded to the transverse beam (such as a height control valve linkage bracket) the entire lower control arm assembly MUST be replaced.

**WARNING** Failure to replace the lower control arm assembly when welds have been made to the transverse beam could cause component failure and loss of vehicle control which, if not avoided, could result in death or serious injury.

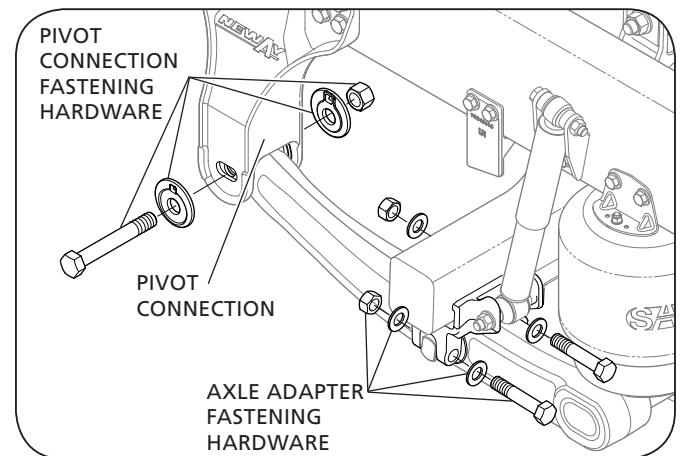
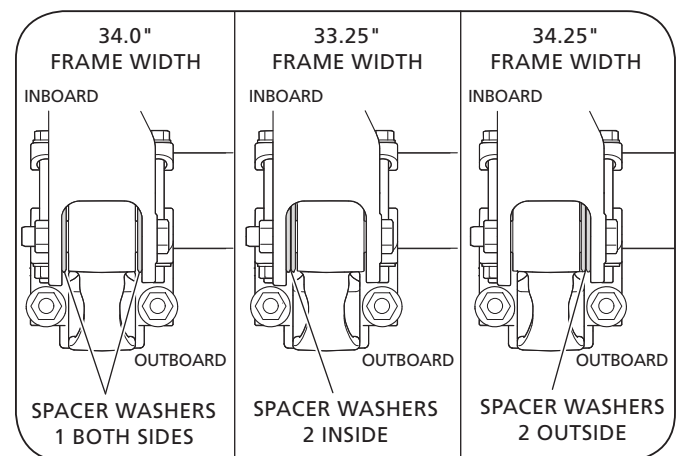
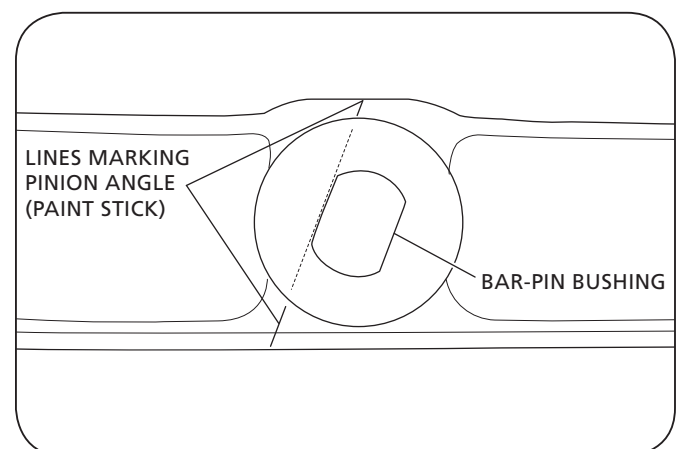
**Figure 31**

**Figure 32**

**Figure 33**

- Lubricate the new replacement bushings with a approved rubber lubricant (such as P80 Lubricant).

**IMPORTANT:** DO NOT use an oil-based lubricant, soap or brake fluid to lubricate the replacement bushings as they can damage the rubber.

- Orient the pivot connection bushings so that the bushing voids are positioned at the top and bottom of the bushings as illustrated in **(Figure 34)**.
- Using the hydraulic press or the SAF-HOLLAND® Bushing Service Tool, press the new replacement bushings into the lower control arm assembly **(Figure 34)**.

**IMPORTANT:** Use the line marked in Step 10 to install the new replacement bar-pin bushing in the same pinion angle as the replaced bushing.

**IMPORTANT:** Be sure to center the bushings in the receptacles of the lower control arms **(Figure 35)**.

- Using floor jacks to raise the entire lower control arm assembly, re-assemble the lower control arm assembly to the frame brackets and axle adapters **(Figure 36)**.

**IMPORTANT:** Install the new spacer washers in between the frame bracket flanges and the pivot bushing of the lower control arm assembly in the same positions as they were removed **(Figure 32)**.

- Using new hardware, re-assemble the pivot connection hardware and torque according to the specifications listed in Section 16.
- Remove the two (2) front floor jacks. DO NOT remove the rear floor jack under the transverse beam.
- Re-assemble the lower control arm assembly to the axle adapters **(Figure 36)**.
- Torque the axle connection bar pin hardware according to the specifications listed in Section 16.
- Remove the floor jack from under the transverse beam.

**Figure 34**

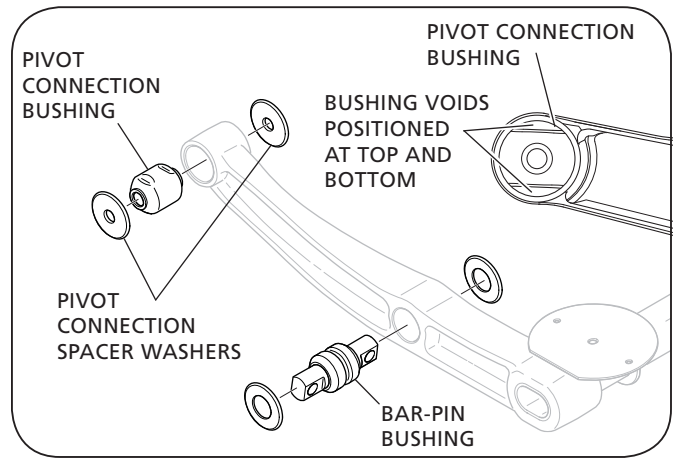

**Figure 35**

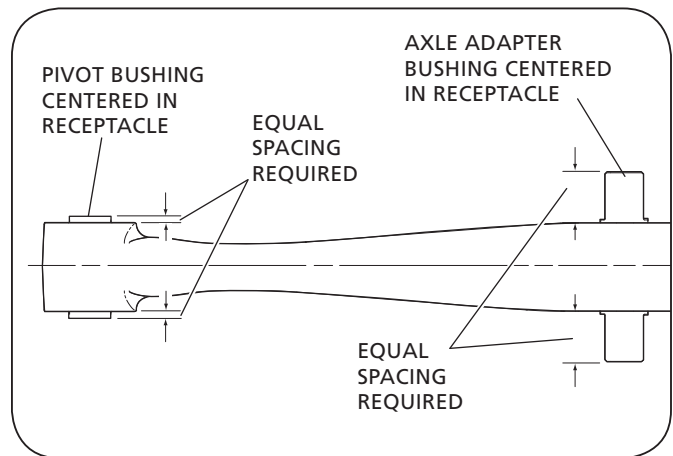

**Figure 36**

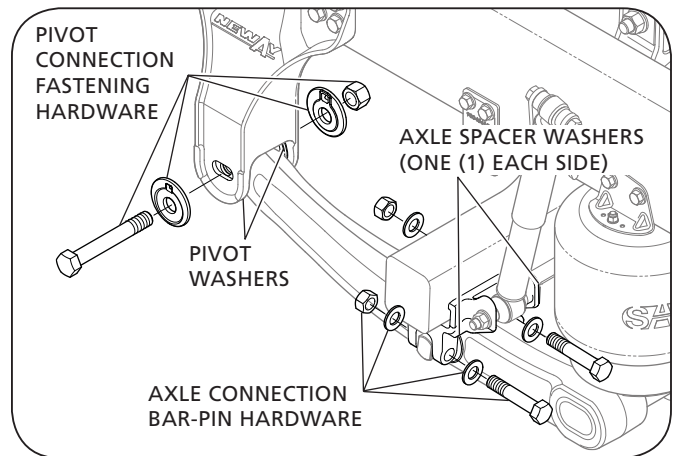



25. Re-connect the air springs, shock absorbers (**Figure 37**) and height control valve lower link and torque hardware according to the specifications listed in Section 16.
26. Re-install the tires and any remaining components and torque the tire hardware according to the wheel manufacturer's and/or OEM's specifications.
27. Remove the floor jack supporting the axle bowl.
28. Raise the rear of the vehicle using the vehicle's lift points to remove the jack stands under the vehicle frame. Refer to procedures provided by the vehicle OEM.
29. Increase the suspension air system reservoir pressure in excess of 70 psig (4.83 bars) and check for leaks. All air springs should inflate and raise the suspension to the proper ride height.
30. Check the ride height and make sure it is within  $\pm .25"$  (6 mm) of design specification and adjust as necessary. Refer to the ride height adjustment instructions shown in Section 6.
31. Check the alignment of the suspension per vehicle OEM instructions. If re-alignment is necessary, refer to the alignment procedures described in Section 7.

**Figure 37**

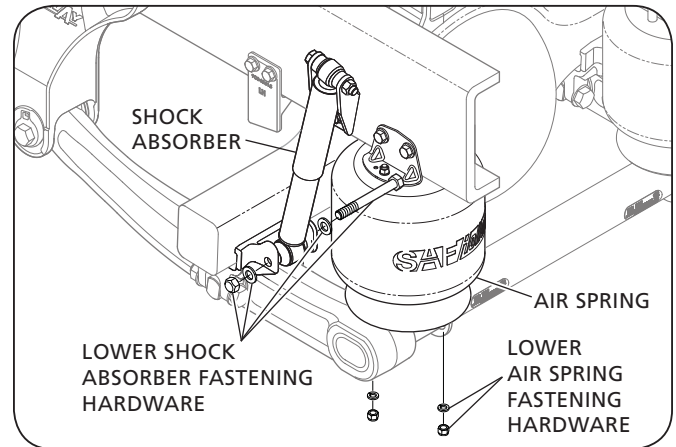

## 12. V-Rod Bushing Replacement

1. With the vehicle unloaded and/or trailer disconnected on a level surface, chock the front tires to prevent the vehicle from rolling forward or backward.
2. Raise the rear of the vehicle using the vehicle's lift points. Refer to procedures provided by the vehicle OEM.
3. Support the vehicle frame using the jack stands (**Figure 38**).

**WARNING** Failure to properly support the vehicle prior to commencing work could create a crush hazard which, if not avoided, could result in death or serious injury.

4. Using a floor jack support the axle at the axle bowl and block the axle to prevent it from rotating when the V-Rod is removed from the upper axle adapter.
5. Exhaust all air from the system by disconnecting the link from the lower connection of the height control valve and pulling down on the link (**Figure 39**). Refer to the height control valve manufacturer's instructions for further information.
6. Disconnect the air supply line from the air spring.

**NOTE:** If the air spring has a leak and is deflated, Step 7 MUST still be performed.

7. Using the floor jack, lower the suspension until the shock absorbers are fully extended.
8. Remove and discard the fastening hardware connecting the V-Rod to the frame crossmember (**Figure 40**). Refer to Section 4 for SRK-645 for replacement kit.
9. Mark the position of the V-Rod upper axle bracket pinion plate on the bracket with a paint pen so the plate can be re-installed in the same position. Refer to Section 8.1 for additional information.
10. Remove the rear V-Rod attachment bolt from the upper axle bracket (**Figure 39**).

**IMPORTANT:** Be sure the two (2) spacer washers located between the inside faces of the upper axle bracket and side of the V-Rod DO NOT fall out.

**NOTE:** There are backer plates and spacers in between the V-Rod bushing and the frame crossmember. Remove the backer plates and spacers and set aside for re-assembly.

Figure 38

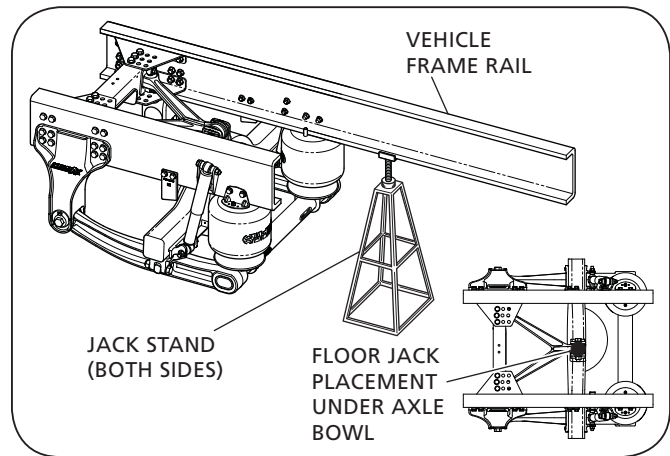

Figure 39

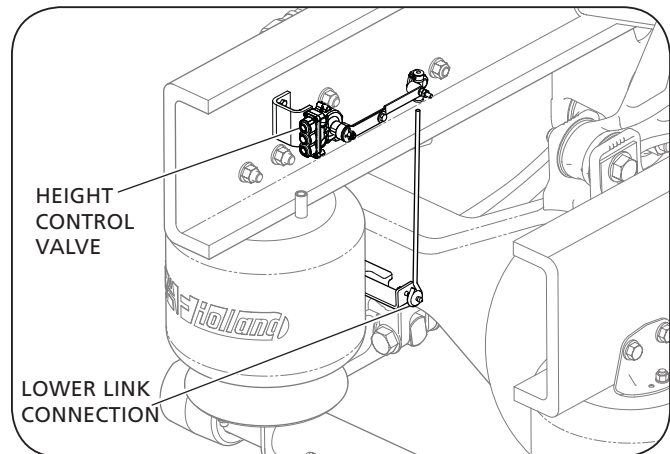
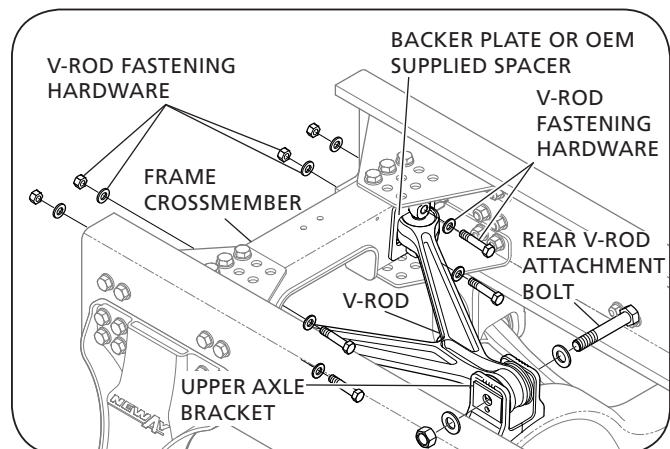

Figure 40



11. Using a paint pen draw a line to mark the angle of the bar-pin bushings as this will be needed for re-assembly (**Figure 41**).
12. Securely mount the V-Rod to a fifteen (15) ton or larger hydraulic press.

**CAUTION** Failure to securely mount the lower control arm assembly support fixtures could allow the lower control arm assembly to shift abruptly which, if not avoided, could result in minor or moderate injury.

13. Press out the old bushings using the hydraulic press (**Figure 42**).

**IMPORTANT:** Press only on the outer jacket of the bushings for removal (**Figure 42**).

**IMPORTANT:** Be sure to note the position of the two (2) bar-pin bushings. This will be needed when the V-Rod is re-assembled later.

14. Clean out all foreign material from the bushing receptacles in the V-Rod.

**NOTE:** DO NOT use any open flame or other heat source to remove the bushings.

15. Visually inspect all components for wear, cracks or failed welds and replace as necessary.

**WARNING** Failure to replace components that are worn, cracked or have failed welds could cause component failure and loss of vehicle control which, if not avoided, could result in death or serious injury.

16. Apply Loctite® 603 to the outer metal jacket of the new replacement bushings.

**IMPORTANT:** DO NOT use an oil-based lubricant, soap or brake fluid to lubricate the replacement bushings as they can damage the rubber.

17. Using the hydraulic press the new replacement bushings into the V-Rod.

**IMPORTANT:** Press ONLY on the outer jacket of the bushings for removal (**Figure 42**).

**IMPORTANT:** Be sure to install the new bar-pin bushings in the same orientation as the replaced bushings.

**IMPORTANT:** Be sure to center the bushings in the receptacles of the V-Rod (**Figure 43**).

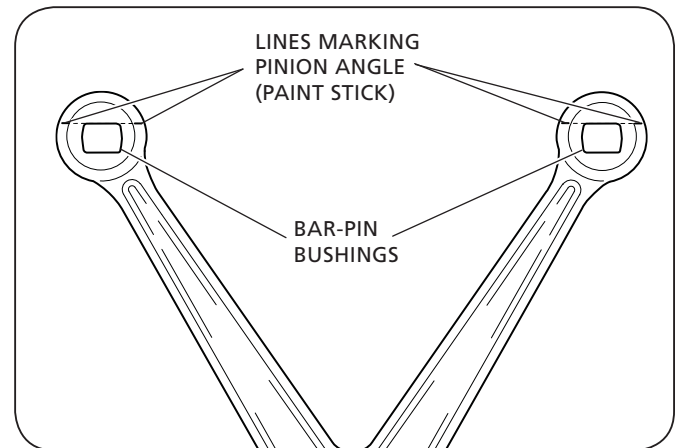
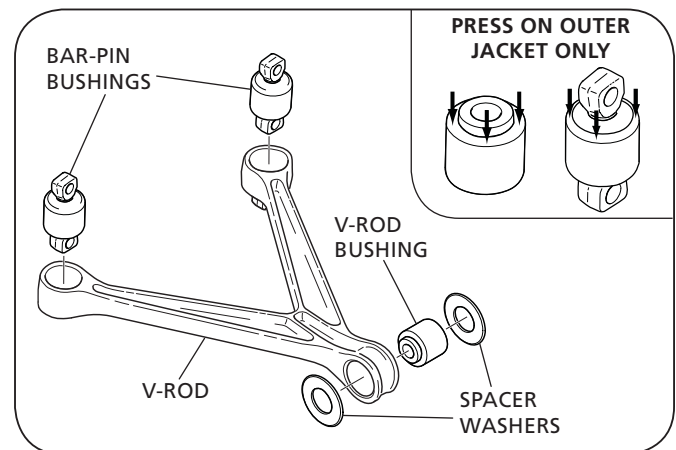
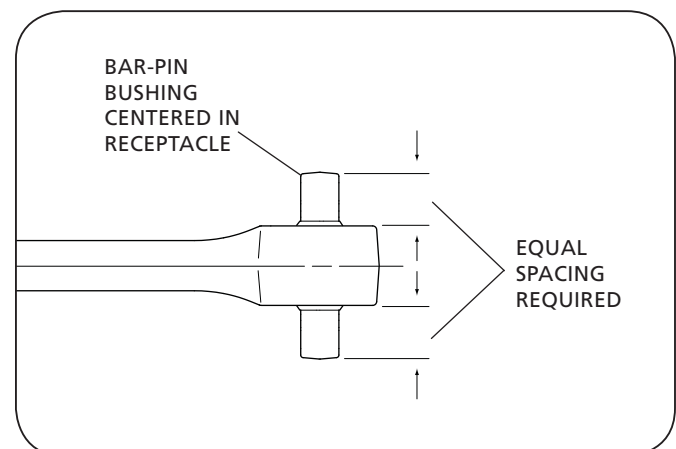
**Figure 41**

**Figure 42**

**Figure 43**

- Using new fastening hardware, re-assemble the V-Rod to the frame crossmember (**Figure 44**).

**IMPORTANT:** Ensure the backer plates and spacers are installed behind the V-Rod bar-pin bushings.

- Torque the frame crossmember fastening hardware according to the torque specifications listed in Section 14.
- Position the rear of the V-Rod into the upper axle bracket (**Figure 45**).

**IMPORTANT:** Be sure to re-assemble the spacer washer in between the V-Rod and the inside of the upper axle bracket.

- Using new fastening hardware, re-assemble the V-Rod to the upper axle bracket.
- Torque the upper axle bracket fastening hardware according to the torque specifications listed in Section 16.
- Using the floor jack, raise the suspension.
- Re-connect the air supply line to the air spring and the lower link connection of the height control valve.
- Increase the suspension air system reservoir pressure in excess of 70 psig (4.83 bars) and check for leaks. All air springs should inflate and raise the suspension to the proper ride height.
- Remove the floor jack under the axle bowl and blocking from the axle.
- Raise the rear of the vehicle using the vehicle's lift points to remove the jack stands under the vehicle frame. Refer to procedures provided by the vehicle OEM.
- Check the ride height and make sure it is within  $\pm .25"$  (6 mm) of design specification and adjust as necessary. Refer to the ride height adjustment instructions shown in Section 6.
- Check the alignment of the axle/suspension per vehicle OEM instructions. If realignment is necessary, refer to the alignment procedures described in Section 7.

**Figure 44**

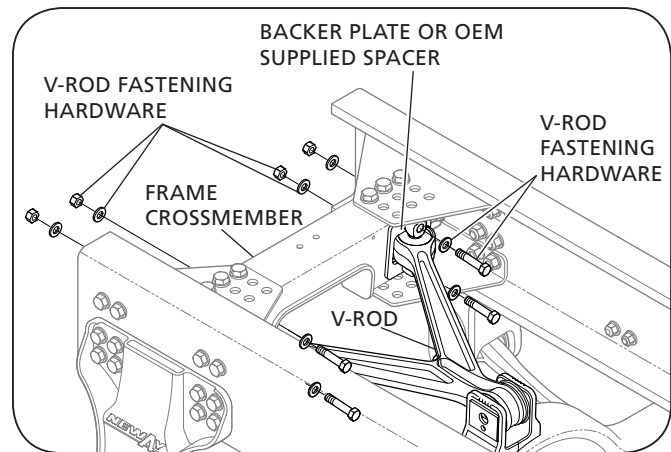

**Figure 45**

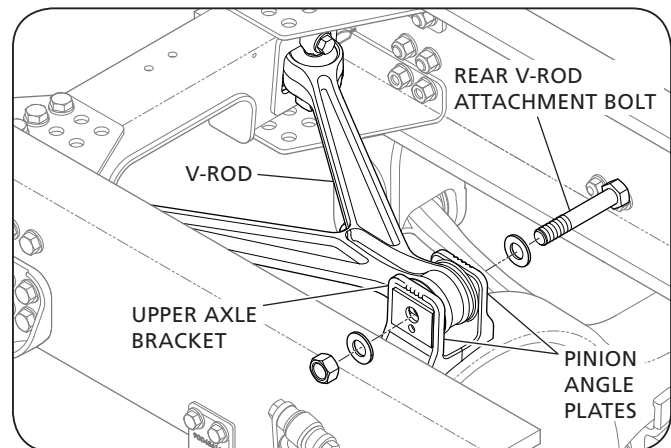

## 13. Frame Bracket Replacement

**IMPORTANT:** The Neway® ADZ Series Suspension frame brackets are symmetrical and can be installed on either side of the vehicle. Typically an adjustable frame bracket is located on the road side of the vehicle and a non-adjustable frame bracket on the curb side of the vehicle. Be sure one (1) non-adjustable and one (1) adjustable frame bracket is used for each suspension.

1. With the vehicle unloaded and/or trailer disconnected on a level surface, chock the front tires to prevent the vehicle from rolling forward or backward.
2. Raise the rear of the vehicle using the vehicle's lift points. Refer to procedures provided by the vehicle OEM.
3. Support the vehicle frame using jack stands and remove the tires (**Figure 46**).

**⚠ WARNING** Failure to properly support the vehicle prior to commencing work could create a crush hazard which, if not avoided, could result in death or serious injury.

4. Using floor jacks; support the axle at the axle bowl and the lower the control arm assembly at the transverse beam (**Figure 46**).

**IMPORTANT:** Be careful NOT to gouge or mark the transverse beam with the floor jack.

**⚠ WARNING** Failure to avoid gouging or marking the transverse beam could cause component failure and loss of vehicle control which, if not avoided, could result in death or serious injury.

5. Using two (2) floor jacks, support both sides of the lower control arm assembly near the pivot connection (**Figure 46**).

**⚠ WARNING** Failure to properly support the suspension during maintenance could allow the suspension to fall which, if not avoided, could result in death or serious injury.

6. Exhaust all air from the system by disconnecting the link from the lower connection of the height control valve and pulling down on the link (**Figure 47**). Refer to the height control valve manufacturer's instructions for further information.
7. Disconnect the air supply line from the air spring.

**NOTE:** If the air spring has a leak and is deflated, Step 7 MUST still be performed.

8. Remove and discard the pivot connection bolt and fastening hardware at the pivot connection (both sides) (**Figure 48**). Refer to SRK-643 and -644 in Section 4 for replacement hardware.

**IMPORTANT:** Be sure to note the positions of the spacer washers between the frame bracket flanges and the pivot end of the lower control arm assembly (**Figure 32 and 48**).

**Figure 46**

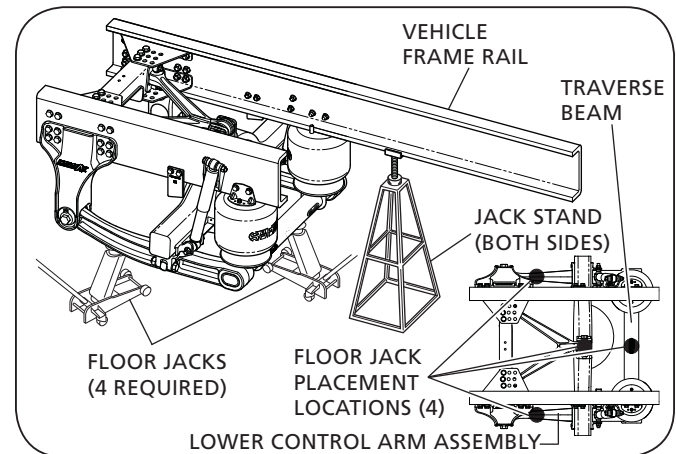

**Figure 47**

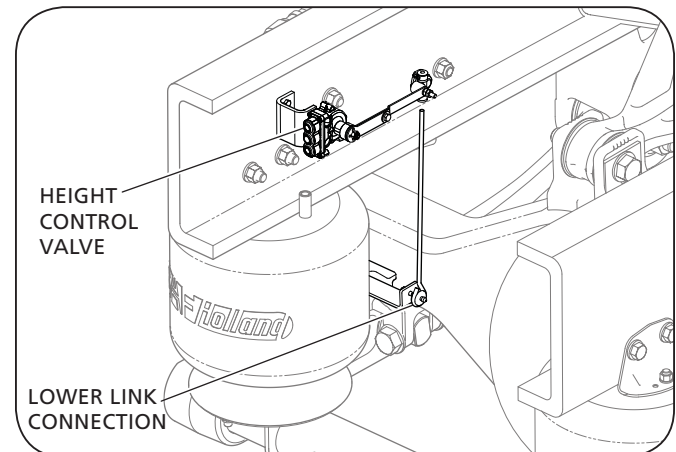

**Figure 48**

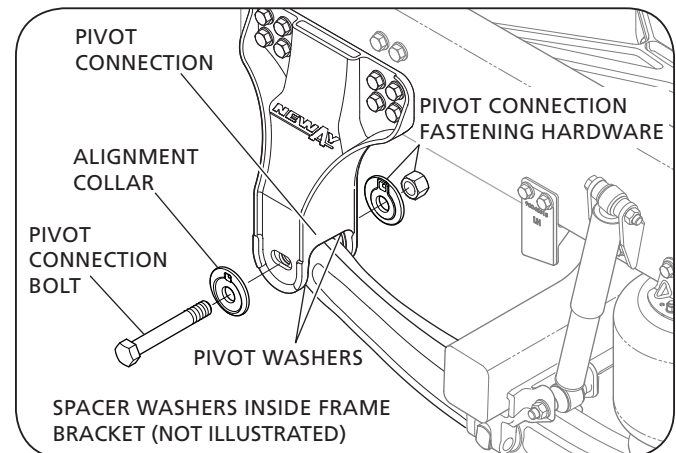

- Remove and discard the frame bracket fastening hardware from the frame rail (**Figure 47**).

**CAUTION** When removing both frame brackets, remove one at a time or support the crossmember to prevent disassembly, which if not avoided, could result in minor or moderate injury.

- Slide the frame bracket off of the frame rails and lower the control arm assembly (**Figure 48**).

**IMPORTANT:** DO NOT lower the lower control arm assembly to remove the frame brackets.

**NOTE:** Mark which side of the suspension the fixed and adjustable frame brackets are located as this will be needed for re-assembly.

**IMPORTANT:** NEVER attempt to repair a cracked or worn frame bracket.

**WARNING** Failure to replace a cracked or worn frame bracket could cause loss of vehicle control which, if not avoided, could result in death or serious injury.

- Slide the new frame bracket into the proper position on the frame rail and lower the control arm assembly (**Figure 48**).
- Assemble the new frame bracket to the frame rails using new Grade 8 minimum bolts with a hardened washer under the head of each bolt and nut (**Figure 47**) and torque according to the OEM specifications.
- Using the new fastening hardware assemble the new frame bracket to the lower control arm assembly at the pivot connection (**Figure 49**) and torque according to the specifications listed in Section 16.

**IMPORTANT:** Be sure to re-assemble the spacer washers in the proper positions between the frame bracket flanges and the pivot end of the lower control arm assembly. Refer to (**Figure 32**).

- Remove the two (2) front floor jacks. DO NOT remove the rear floor jacks under the axle bowl and transverse beam.
- Re-connect the air springs and height control valve lower link, and torque hardware according to the specifications listed in Section 16.
- Re-install the tires and any remaining components and torque the tire hardware according to the wheel manufacturer's and/or OEM's specifications.
- Remove the floor jacks supporting the axle bowl and transverse beam.

**Figure 47**

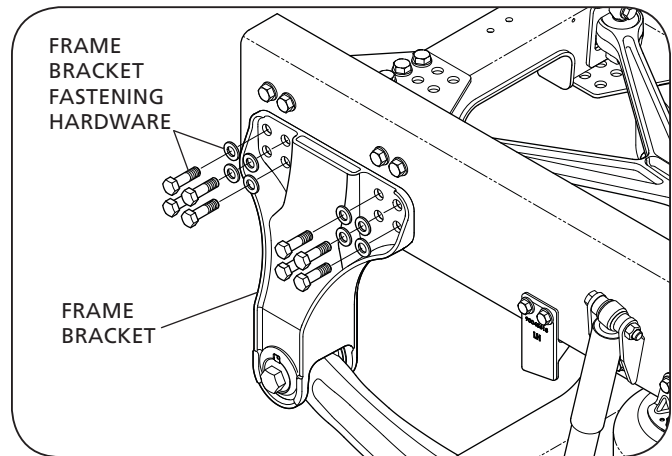

**Figure 48**

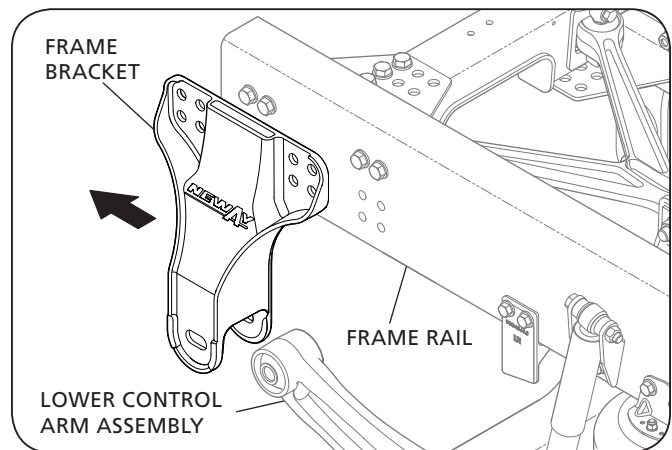

**Figure 49**

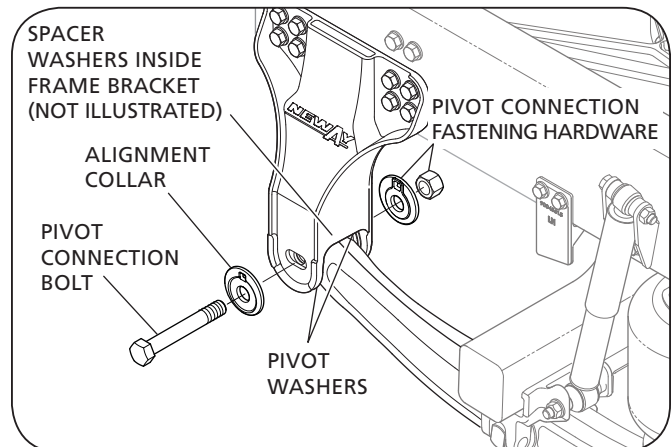

18. Raise the rear of the vehicle using the vehicle's lift points to remove the jack stands under the vehicle frame. Refer to procedures provided by the vehicle OEM.
19. Increase the suspension air system reservoir pressure in excess of 70 psig (4.83 bars) and check for leaks. All air springs should inflate and raise the suspension to the proper ride height.
20. Check the ride height and make sure it is within  $\pm .25$ " (6 mm) of design specification and adjust as necessary. Refer to the ride height adjustment instructions shown in Section 6.
21. Re-align the ADZ suspension according to the axle alignment procedures shown in Section 7.

### 14. Crossmember End Plate Replacement (Figure 50)

Part Number: 48100543

SRK-677

ITEM	DESCRIPTION	PART NUMBER	QTY.
1	End Plate, Reinforced, Left-Hand	90549359	2
2	End Plate, Reinforced, Right-Hand	90549361	2
3	Bolt, Hex, M20 x 2.5" x 60, Class 10.9	M3900010	12
5	Nut, Hex, Nylon Locking, M20 x 2.5", Class 10	M3900011	12
6	Backer Plate	90034740	2

### 15. Replacement Procedures

**IMPORTANT:** SAF-HOLLAND® recommends replacement of ALL end plates even if only one end plate is found to be cracked during visual inspection.

**NOTE:** Prior to replacement determine and obtain OEM hardware for fastening through the frame rail. When ordering parts, use OEM hardware and allow for an increase in joint thickness of .188" (4.8 mm). Frame attaching hardware should provide a minimum of 30,000 lbs. clamp load for SAE Grade 8 3/4"-10 and 34,100 lbs. clamp load for 20-2.5 Class 10.9 metric.

**NOTE:** Removal of the fifth wheel assembly may be necessary to access the crossmember mounting hardware (Figure 51). If removal is necessary, contact the vehicle OEM for removal procedures and replacement hardware prior to performing end plate replacement.

Figure 50

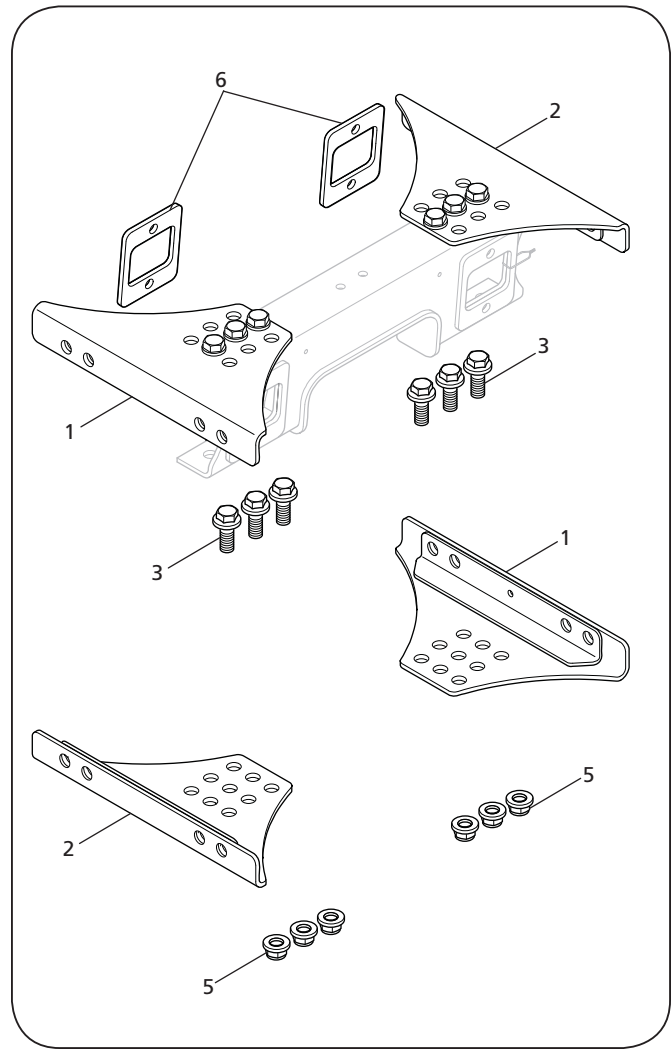
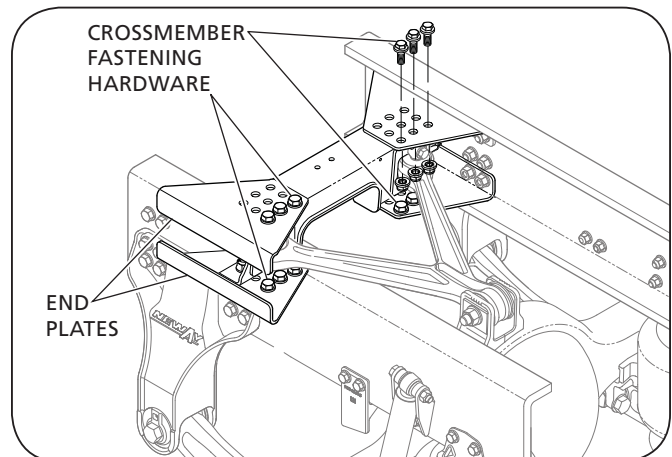

Figure 51





1. With the vehicle unloaded and trailer disconnected on a level surface, chock the front tires to prevent the vehicle from rolling forward or backward.
2. Support the frame with jack stands (**Figure 52**).

**⚠ WARNING** Failure to properly support the vehicle prior to commencing work could create a crush hazard which, if not avoided, could result in death or serious injury.

3. Using a floor jack support the axle at the axle bowl (**Figure 52**) and block the axle to prevent it from rotating when the bolts are removed from the crossmember assembly.
4. Exhaust all air from the suspension system by disconnecting the link from the lower connection of the height control valve and pulling down on the link (**Figure 53**). Refer to the height control valve manufacturer's instructions for further information.

**IMPORTANT:** Determine if any hoses and/or electrical lines are routed through the area where replacement will be performed. Take precaution to ensure that the hoses and/or electrical lines will NOT be damaged.

**Figure 52**

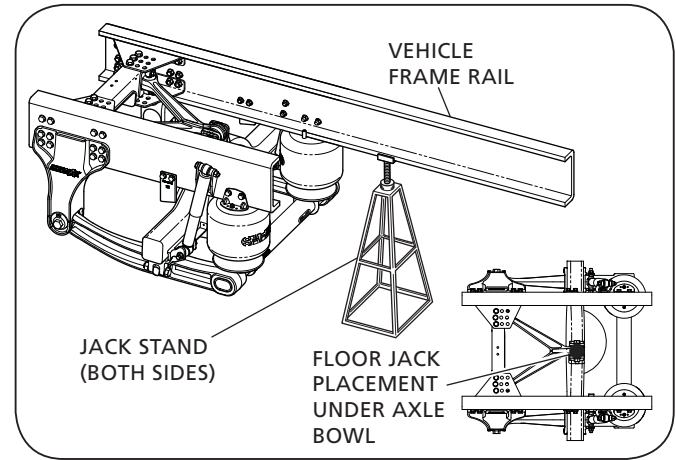

**Figure 53**

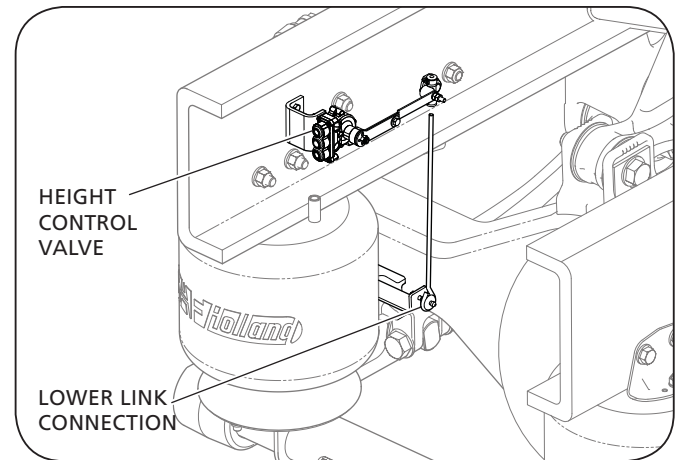

- Clean the exposed fastener threads of dirt and/or paint before loosening. Loosen the V-Rod fastening hardware attached to the crossmember center channel to reduce binding during the end plate removal and installation (**Figure 54**). DO NOT remove V-Rod hardware.
- Note the orientation (bolt head up) and position of the crossmember fastening hardware that attaches the lower end plates to the center channel. Remove and discard the crossmember fastening hardware (**Figure 55**).

**NOTE:** The position of the hardware in the row on the end plate is important to the suspension function (**Figure 56**).

**NOTE:** Crossmembers may include washers.

- Make sure the faces of mating surfaces are clean to ensure proper clamp load.

**Figure 54**

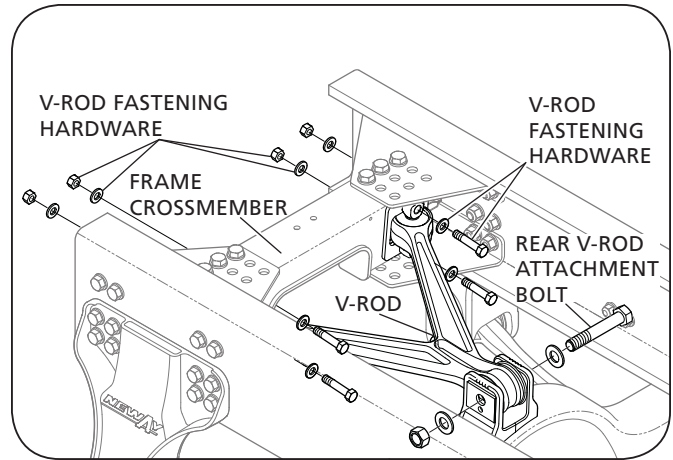

**Figure 55**

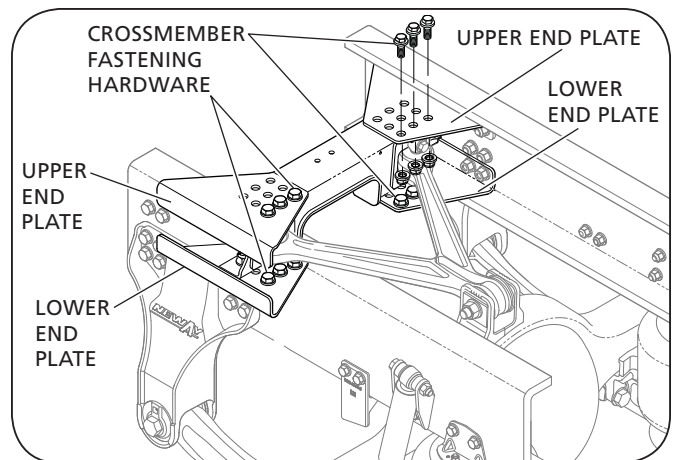

**Figure 56**

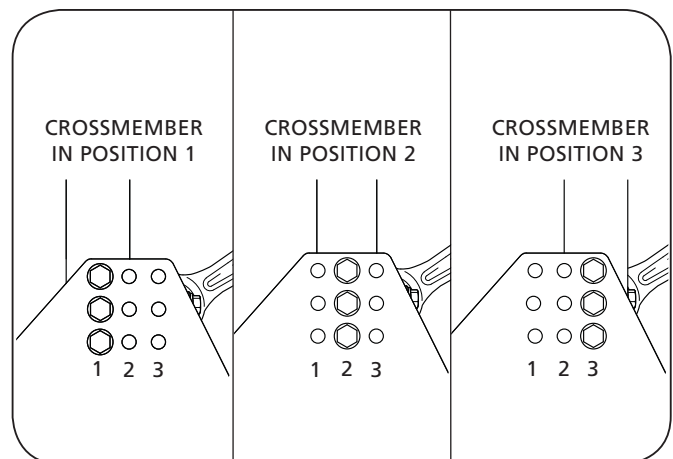

8. Note the orientation of the frame fastening hardware that attaches the lower end plates to frame rail. Remove and discard the frame fastening hardware (**Figure 57**).

**NOTE:** Some bolts may be in reverse orientation to allow clearance of the center channel.

9. Remove the lower end plates from the mating surfaces (**Figure 55**). Use caution NOT to damage surrounding lines and/or wires.

**NOTE:** Make sure to protect hoses and/or electrical lines. If damage to hoses and/or electrical lines occurs, replacement may be required which will add time to replacement procedures.

10. Using new hardware, attach the new reinforced lower end plate to the center channel in the same orientation and position noted in Step 6 (bolt head up). Use caution NOT to damage surrounding lines and/or wires.

**NOTE:** DO NOT tighten fasteners until all fasteners are installed.

11. Install the new frame fastening hardware in the same orientation as noted in Step 8.
12. Once all the fastening hardware is installed, make sure that all mating parts are flat and square. Using a torque wrench, tighten the center channel bolts to 300-380 ft.-lbs. (407-515 N•m).
13. Tighten the frame rail fastening hardware according to OEM torque specifications.

**Figure 57**

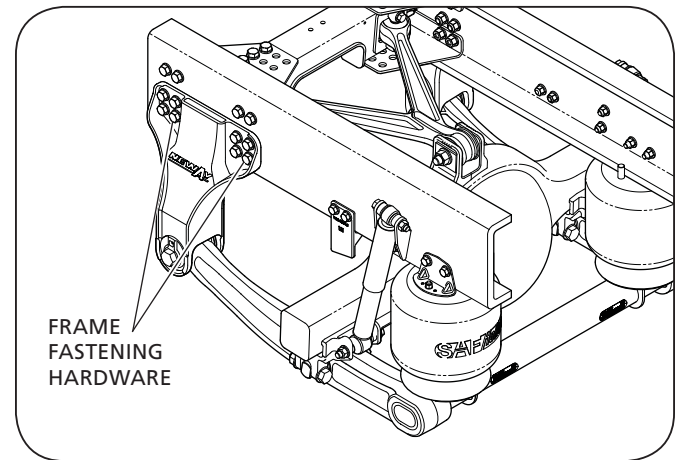

14. Note the orientation (bolt head up) and position of the crossmember fastening hardware that attaches the upper end plates to the center channel. Remove and discard the crossmember fastening hardware (**Figure 58 and 59**).
15. Note the orientation of the frame fastening hardware that attaches the upper end plates to the frame rail. Remove and discard the frame fastening hardware (**Figure 60**).
16. Remove the upper end plates from the mating surfaces (**Figure 58**). Use caution NOT to damage surrounding lines and/or wires.

**NOTE:** Ensure that hoses and electrical lines are protected. If damage to hoses and/or electrical lines occurs, replacement may be required which will add time to replacement procedures.

17. Using new hardware, attach the new reinforced upper end plate to the center channel in the same orientation and position noted in Step 13 (bolt head up). Use caution NOT to damage surrounding lines and/or wires.

**NOTE:** DO NOT torque fasteners until all fasteners are installed.

18. Install the new frame fastening hardware in the same orientation as noted in Step 14.
19. Once all fastening hardware is installed, make sure that all mating parts are flat and square. Using a torque wrench, tighten the center channel bolts to 300-380 ft.-lbs. (407-515 N•m).
20. Tighten the frame rail fastening hardware according to OEM torque specifications.

**Figure 58**

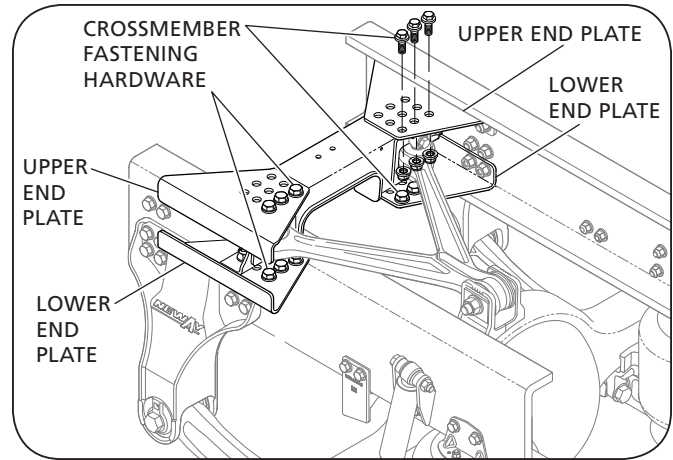

**Figure 59**

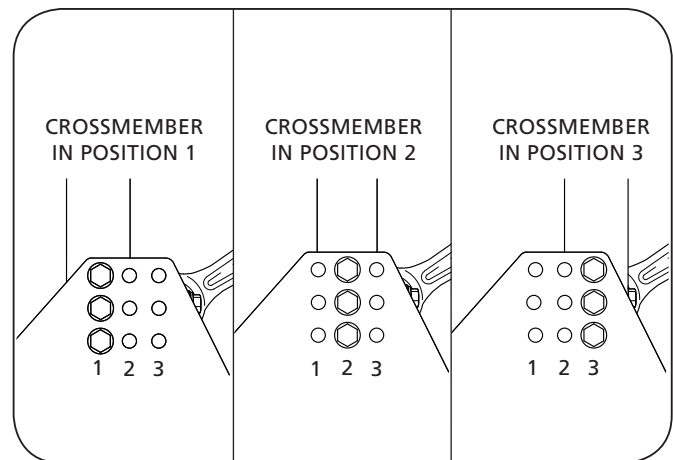

**Figure 60**

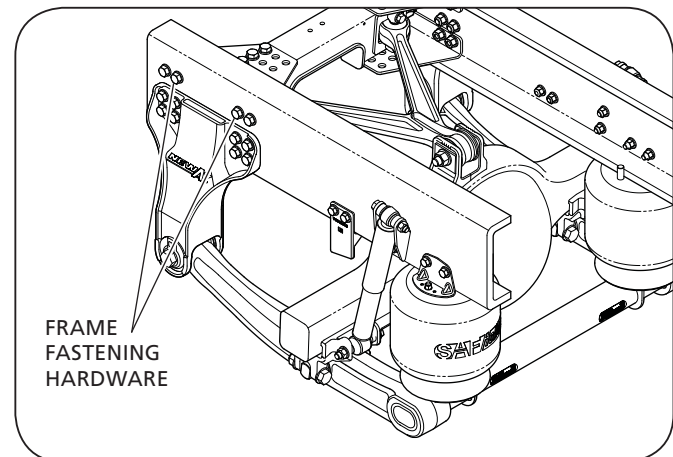

21. When re-assembling the V-Rod at the crossmember, install one (1) additional Item 6 (Backer Plate) against the forward cross member center channel face. The plate thickness is approximately .31" (8mm). Account for this in replacement hardware length specification.
22. Using a torque wrench, tighten the V-Rod crossmember fastening hardware to OEM specifications (**Figure 61**).
23. Reposition any hoses and/or electrical wires that were displaced or repositioned during removal and replacement procedures.
24. Touch up any paint or undercoating of metal that may have been exposed or damaged during the replacement process.
25. Re-connect the height control valve system and re-adjust the ride height following vehicle OEM or height control valve OEM procedures.
26. Remove the floor jack supporting the axle bowl.
27. Raise the rear of the vehicle using the vehicle's lift points and remove the jack stands from under the vehicle frame. Refer to the procedures provided by the vehicle OEM.
28. Increase the suspension air system reservoir pressure above 70 psig (4.83 bars) and check for leaks. All air springs should inflate and raise the suspension to the proper ride height.
29. Check the ride height and make sure it is within  $\pm .25"$  (6 mm) of design specification and adjust as necessary. Refer to the ride height adjustment instructions described in Section 6.
30. Check the alignment of the suspension per vehicle OEM instructions. If re-alignment is necessary, refer to the alignment procedures described in Section 7.

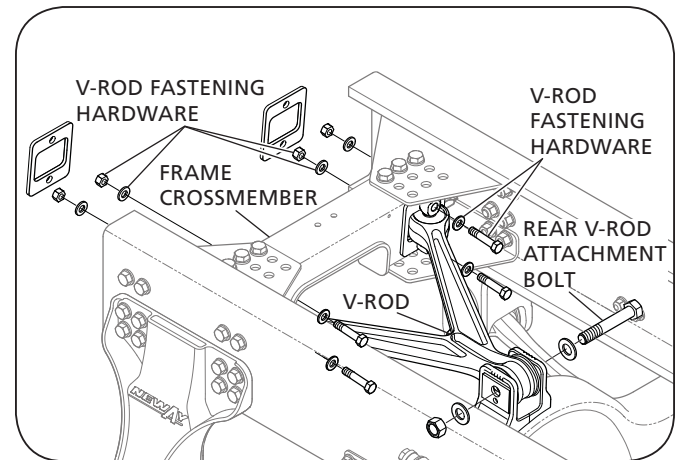
**Figure 61**

## 16. Torque Specifications

COMPONENT	FASTENER SIZE	NOMINAL TORQUE VALUE	TORQUE RANGE
ADZ Pivot Connection	1 - 1/8"-7 (28.6 mm)	634 ft.-lbs. (860 N•m)	571-697 ft.-lbs. (773-945 N•m)
Upper and Lower Shock Mount	3/4"-10 (19.1 mm)	158 ft.-lbs. (214 N•m)	142-174 ft.-lbs. (193-235 N•m)
Upper and Lower Air Spring	1/2"-13 (12.7 mm)	37 ft.-lbs. (50 N•m)	33-41 ft.-lbs. (45-55 N•m)
Upper Air Spring	3/4"-16 (19.1 mm)	37 ft.-lbs. (50 N•m)	33-41 ft.-lbs. (45-55 N•m)
V-Rod Connection at Axle	1"-8 (25.4 mm)	634 ft.-lbs. (860 N•m)	571-697 ft.-lbs. (773-945 N•m)
Axle Adapter Connection – Bar-pin	1"-8 (25.4 mm)	634 ft.-lbs. (860 N•m)	571-697 ft.-lbs. (773-945 N•m)
Crossmember Wing Plates to Crossmember Center Channel	M20-2.5	340 ft.-lbs. (461 N•m)	300-380 ft.-lbs. (407-515 N•m)

**NOTE:** Torque specifications listed above are with clean lubricated/coated threads, supplied by SAF-HOLLAND®.

**IMPORTANT:** The use of special lubricants with friction modifiers, such as Anti-Seize or Never-Seez®, without written approval from SAF-HOLLAND® Engineering, will void warranty and could lead to over torquing of fasteners or other component issues.

### General Information

1. The torque specifications listed throughout the manual are applied to the nut and NOT the bolt.

**IMPORTANT:** Most of the fasteners used in this suspension are Grade 8 bolts and Grade C nuts. These fasteners have the strength and hardness properties required for their particular function. They must be replaced with fasteners of the same grade, size and form as the original in order to prevent failure (**Figure 62**).

**⚠ WARNING** Failure to use the proper fasteners when servicing the suspension could cause component failure which, if not avoided, could result in death or serious injury.

**⚠ WARNING** Failure to properly torque all fasteners will result in component failure which, if not avoided, could result in death or serious injury.

2. All fasteners MUST be torqued after the first 100 hours of service or 5,000 miles (8,000 km).
3. Refer to vehicle OEM for torque specifications for vehicle frame fastener hardware.

Figure 62

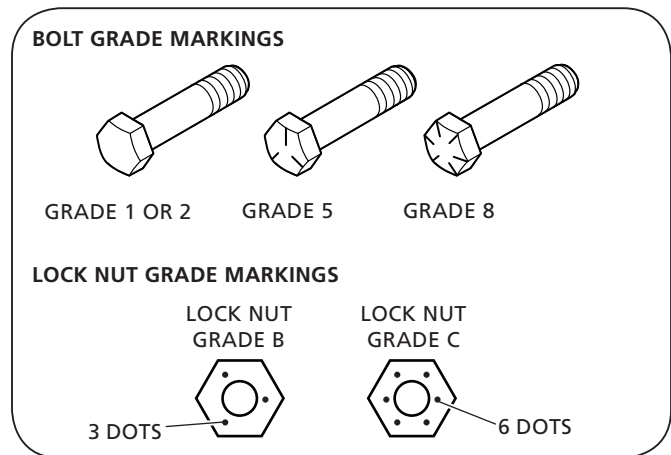

## 17. Routine Maintenance and Daily Inspection

### 17.1 Daily Inspection

1. Daily or before each trip, check the suspension to be sure it is fully operational and visually free of any obvious signs of failure in any major component.
2. Visually inspect air springs for sufficient and equal pressure and that the suspension is set at the proper ride height. Refer to ride height measurement and re-setting instructions as described in Section 6. Service as necessary.

### 17.2 Initial 5,000 Miles (8,000 km) or 100 Hours of Service

1. The suspension ride height (underside of frame to centerline of axle) **MUST BE WITHIN  $\pm 0.25$ " OF RECOMMENDED DESIGN HEIGHT.** Refer to the ride height measurement and re-setting instructions as described in Section 6. Service as necessary.

**CAUTION**

An improperly set ride height could result in suspension component damage and/or poor vehicle ride performance.

2. After initial 5,000 miles (8,000 km) or 100 hours of service, inspect bolts and nuts at the pivot connections, frame crossmember connections, V-Rod connections and axle connections to ensure they are properly torqued. Check all other nuts and bolts for proper torque. Re-torque as necessary according to the specifications listed in Section 16.

**IMPORTANT:** It is recommended to monitor torque of any joint that required re-torque at the 5,000 mile/100 hours of service interval. Continue to monitor these joints daily until no change occurs at any joint that required re-torquing. Establish a re-check interval equivalent to findings of this monitoring.

**WARNING**

Failure to maintain proper joint torque could lead to joint failure which, if not avoided, could result in death or serious injury.

3. With the vehicle on level surface and air pressure in excess of 70 psig, verify that all air springs are of sufficient and equal firmness.
4. Visually check all air control system fittings for air leaks by applying a soapy water solution and checking for bubbles at all air connections and fittings.

### 17.3 Routine Maintenance - 50,000 Miles (80,000 km) / 1,000 Hours of Service, or as Needed

Inspect suspension components per 5,000 mile (8,000 km) inspection. Check all other suspension components for any sign of damage, looseness, torque loss, wear or cracks. To prevent equipment breakdown; repair, tighten or replace damaged or loosened components.

### 17.4 Visual Inspection Procedure

**IMPORTANT:** A schedule for physical and visual inspections should be established by the operator based on severity of operation or damage to the vehicle could occur.

**IMPORTANT:** During each pre-trip and safety inspection of the vehicle, a visual inspection of the suspension should be done or damage to the vehicle could occur.

**CAUTION**

Failure to correct out of specification conditions during routine inspections could result in poor suspension performance which, if not avoided, could result in damage to trailer components.

Visually check for:

- Bolt Movement – loose dirt, rust or metal wear around bolt head and nut.
- Air Springs – clearances, wear damage, and proper inflation.
- Shock Absorbers – leaking or damaged.
- Cracked Parts or Welds.

## 18. Troubleshooting

PROBLEM	POSSIBLE CAUSE	SOLUTION
All air springs are flat	Insufficient air pressure in the vehicle air system	Check the air pressure gauge on instrument panel. If air pressure is low, run the engine until a minimum pressure of 70 psig (4.83 bars) is indicated on the gauge. If air pressure is 70 psig (4.83 bars) or above and the air springs are NOT inflated, the problem may be with the pressure protection valve.
	Air leakage from the suspension air system or the air brake system	Visually check all air control system fittings by applying a soapy water solution and checking for bubbles at all air connections and fittings. Check for loose or damaged fittings, air lines, air springs, brake actuators or control valve. Tighten loose fittings to stop leakage and/or replace worn or damaged parts as necessary.
Air spring(s) deflate rapidly when vehicle is parked	Air leakage from the suspension air system	Test for air leakage due to loose fittings between air tank and air suspension or damaged air lines, air springs or height control valve. Visually check all air control system fittings by applying a soapy water solution and checking for bubbles at all air connections and fittings. Tighten loose fittings to stop leakage and/or replace worn or damaged parts as necessary.
Ride height too high or too low	Height control valve out of adjustment	Re-adjust vehicle ride height using the height control valve. Refer to the height control valve manufacturer's instructions for adjustment.
Air spring(s) ruptured	Tires, rims, chains or other objects are rubbing against the air spring	Check for proper clearance between the air spring and the tire. If the tire, rim, chains or other objects contact the inflated air spring when the vehicle is loaded, a narrower set of tires and rims are necessary to provide clearance for tires with chains (contact your vehicle manufacturer for recommendations).
Air spring(s) fail	Continual or repeated over-extension of the air spring(s)	Check that the proper shock absorber for your vehicle's application is installed. Visually inspect for broken or loose shock absorbers or shock absorber mounting brackets. Re-connect loose parts and replace any worn or damaged parts as necessary. Check the adjustment of the height control valves. Refer to the height control valve manufacturer's instructions for adjustment.
	Air spring(s) worn out	Replace the air spring(s). <b>NOTE:</b> If the air spring piston contacts the upper bead plate, it may fracture and leak air. Ensure the axle stops are installed properly and limit the suspension up travel to specification.
	Axle stop NOT installed or installed incorrectly	Check for proper axle up travel per vehicle OEM's specifications. Install axle stops according to the vehicle OEM's recommendations.
Air spring(s) fail to fully deflate when all weight is removed from the suspension	Restricted air line(s) between the height control valve and the air spring(s)	Disconnect the height control valve linkage and rotate the actuating lever to the 45° down position. If the air spring(s) remain inflated, check for pinched or blocked line(s).
Shock absorber(s) fail	Elongated eyes/over-extension	Inspect for mislocated shock brackets and installation of incorrect shocks. Replace as necessary.
Excessive tire wear	Axles misaligned	Re-align axles per vehicle manufacturer's recommendations. The ADZ Series Suspension has alignment collars located on the frame bracket pivot connections for use in axle alignment. Re-torque bolts after re-alignment is completed according to the specifications listed in Section 16.
	Worn pivot or axle bushings	Re-bush with proper bushing, refer to replacement instructions.



PROBLEM	POSSIBLE CAUSE	SOLUTION
Front pivot connection worn or loose	Worn bushings or loss of pivot bolt torque	<p>Check pivot connection for worn bushings or looseness by inserting a 2' pry bar between the frame bracket and the nose of the lower control arm assembly. Visually check for movement while moving the pry bar back and forth. Exercise care NOT to gouge or damage the components while prying back and forth. If .25" or more movement is detected, disassemble the pivot connection and visually inspect the rubber bushing.</p> <p>Check pivot connection bolt to specifications in Section 16. If it DOES NOT fall within specification, perform bushing replacement procedure per Section 11.</p> <p>Replace the pivot connection bushing if wear is detected.</p> <p>If the bushing appears to be in proper working condition, re-assemble the pivot connection and, with the suspension set at the proper ride height, torque the pivot connection to the specification listed in Section 16.</p>
	Worn out due to length of service	Replace pivot connection.
	Axle alignment loose	Replace worn parts, realign and torque to specification listed in Section 14.
Vehicle unstable or handles poorly	Loose frame bolts or attachments	Tighten frame bolts and attaching parts to proper specifications.
	Cracked or loose frame crossmembers	Repair or replace damaged frame members and torque all nuts and bolts to proper torque specifications.
	Improper ride height	Inspect the ride height. Re-adjust as necessary.
	Incorrect Bushings	Replace as necessary.
	Loose or worn pivot connection	<p>Check pivot connection for worn bushings or looseness by inserting a 2' pry bar between the frame bracket and the nose of the lower control arm assembly. Visually check for movement while moving the pry bar back and forth. Exercise care NOT to gouge or damage the components while prying back and forth. If .25" or more movement is detected, disassemble the pivot connection and visually inspect the rubber bushing.</p> <p>Replace the pivot connection bushing if wear is detected.</p> <p>If the bushing appears to be in proper working condition, reassemble the pivot connection and, with the suspension set at the proper ride height, torque the pivot connection to the specification listed in Section 14.</p> <p><b>NOTE:</b> It will be necessary to re-align the axle after loosening the pivot bolt on the adjustable (slotted) frame bracket.</p>
	Loose or worn bar-pin axle connection (rubber wear)	<p>Check axle connection for worn bushings or looseness by inserting a 2' pry bar between the bottom of the axle adapter and the lower control arm assembly. Visually check for movement while moving the pry bar back and forth. Exercise care NOT to gouge or damage the components while prying back and forth. If .25" or more movement is detected, disassemble the axle adapter connection and visually inspect the rubber bar-pin bushing.</p> <p>Replace the axle adapter bushing if wear is detected.</p> <p>If the bushing appears to be in proper working condition, reassemble the axle adapter connection and, with the suspension set at the proper ride height, torque the axle adapter connection to the specification listed in Section 16.</p>

\*If problems still persist, contact vehicle OEM or SAF-HOLLAND® Customer Service at 888-396-6501.







From fifth wheel rebuild kits to suspension bushing repair kits, SAF-HOLLAND Original Parts are the same quality components used in the original component assembly.

SAF-HOLLAND Original Parts are tested and designed to provide maximum performance and durability. Will-fits, look-a likes or, worse yet, counterfeit parts will only limit the performance potential and could possibly void SAF-HOLLAND's warranty. Always be sure to spec SAF-HOLLAND Original Parts when servicing your SAF-HOLLAND product.

**SAF-HOLLAND USA • 888.396.6501 • Fax 800.356.3929**  
[www.safholland.us](http://www.safholland.us)

**SAF-HOLLAND CANADA • 519.537.3494 • Fax 800.565.7753**  
**WESTERN CANADA • 604.574.7491 • Fax 604.574.0244**  
[www.safholland.ca](http://www.safholland.ca)

**SAF-HOLLAND MEXICO • 52.55.5362.8743 • Fax 52.55.5362.8743**  
[www.safholland.com.mx](http://www.safholland.com.mx)

[info@safholland.com](mailto:info@safholland.com)