

Installation and Maintenance Manual

BINKLEY[™]

DuraLite[®] Series
Mechanical Suspension

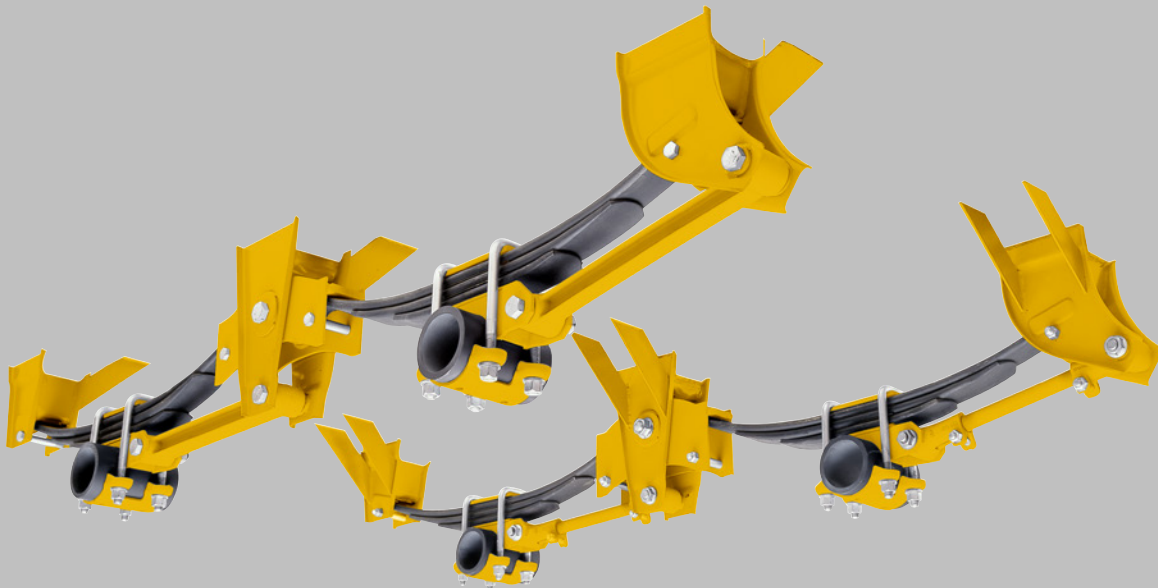

Contents	Page
Introduction.....	2
Warranty.....	2
Notes, Cautions, and Warnings.....	2
Section 1 – General Safety Instructions.....	3
Section 2 – Installation Preparation.....	3
Section 3 – Welding Standards.....	4
Section 4 – Trailer Frame Hanger Brackets Location.....	5
Under Mount Hanger Brackets Installation.....	6
Flange Mount Hanger Brackets Installation.....	7
Straddle Mount Hanger Brackets Installation.....	8
Side Mount Hanger Brackets Installation.....	9
Straddle/Under Mount Brackets Installation.....	10

Contents	Page
Section 5 – Weld Axle Seats to Axle(s) Instructions	
Overslung Axle Style.....	11
Underslung Axle Style.....	12
Section 6 – Leaf Springs and Torque Arms Assembly	
Overslung Axle Style.....	13
Underslung Axle Style.....	14
Section 7 – Axle Alignment.....	15
Section 8 – Final Inspection.....	15
Section 9 – Operating Recommendations.....	15
Section 10 – Maintenance and Service Schedule.....	16
Section 11 – Leaf Spring Selection.....	17
Section 12 – Mounting Height Spring Seat Selections.....	17

Introduction

This manual provides you basic information necessary for the installation and maintenance of the DuraLite® suspension.

IMPORTANT: It is the responsibility of the installer to determine the proper location of the suspension on the frame, provide an adequate structure to support the suspension, ensure adequate clearances with other components, and to determine if the rated suspensions and axle capacity are adequate for the trailer applications.

Warranty

Refer to the complete warranty for the country in which the product will be used. A copy of the written warranty is included with the product and can be found on the SAF-HOLLAND website (www.safholland.us).

Notes, Cautions, and Warnings

You must read and understand all of the safety procedures presented in this manual before starting any work on the suspension.

Proper tools must be used to perform the maintenance and repair procedures described in this manual. Many of these procedures require special tools.

NOTE: In the United States, workshop safety requirements are defined by federal and/or state Occupational Safety and Health Act. Equivalent laws may exist in other countries. This manual is written based on the assumption that OSHA or other applicable employee safety regulations are followed by the location where work is performed.

IMPORTANT: Read this manual before using this product. Keep this manual in a safe location for future reference.



Failure to follow the instructions and safety precautions in this manual can result in death or serious injury.

Throughout this manual, you will notice the terms “NOTE”, “IMPORTANT”, “CAUTION”, and “WARNING” followed by important product information. So that you may better understand the manual, those terms are as follows:

NOTE: Includes additional information to enable accurate and easy performance of procedures.

IMPORTANT: Includes additional information that if not followed could lead to hindered product performance.



Used without the safety alert symbol, indicates a potentially hazardous situation which, if not avoided, could result in property damage.



Indicates a potentially hazardous situation which, if not avoided, could result in minor or moderate injury.



Indicates a potentially hazardous situation which, if not avoided, could result in death or serious injury.

1. General Safety Instructions

Read and observe all Warning and Caution hazard alert messages in this publication. They provide information that can help prevent serious personal injury, damage to components, or both.

⚠ WARNING Failure to properly support the vehicle and axles prior to commencing work could create a crush hazard which, if not avoided, could result in death or serious injury.

Please observe the following safety instructions in order to maintain the operational and road safety of the suspension system.

1. Only the wheel and tire sizes approved by the trailer builder may be used.
2. Before operating vehicle, ensure that the maximum permissible axle load is not exceeded and that the load is distributed equally and uniformly.
3. Observe the operating recommendation of the trailer manufacturer for off-road operation of the installed suspension.

IMPORTANT: The definition of OFF-ROAD means driving on non-asphalted/non-concreted routes, e.g. gravel roads, agricultural and forestry tracks, on construction sites and in gravel pits.

IMPORTANT: Off-road operation of suspensions beyond the approved application design could result in damage and impair suspension system performance.

4. All suspension systems require routine service, inspection and maintenance in order to maintain optimum performance and operational safety as well as an opportunity to recognize wear.
5. In the event of suspension component failure, quickly reduce speed as safely as possible and remove the vehicle from traffic. If unable to remove vehicle from traffic, follow DOT safety requirements regarding emergency situations.
6. Contact a qualified towing and/or service company to assist in repairing vehicle or to move it to a qualified repair facility.

We highly recommend the use of only SAF-HOLLAND Original Parts.

A list of SAF-HOLLAND technical support locations to supply SAF-HOLLAND Original Parts can be found at www.safholland.us or contact SAF-HOLLAND Customer Service at 888-396-6501.

Updates to this manual will be published as necessary online at www.safholland.us.

2. Installation Preparation

The proper installation of the suspension is critical to assure trouble free operation. Before proceeding with suspension installation, check the tire size and trailer design to make sure that there is lateral tire clearance and a vertical tire clearance of at least 4-1/2" (114 mm) when the trailer is empty.

⚠ WARNING Failure to maintain tire clearance between tires and the nearest point of contact on the suspension or vehicle could cause fire or loss of vehicle control which, if not avoided, could result in death or serious injury.

Vertical tire clearance may be adjusted by using different height spring seats or high, medium or low arch springs. HOLLAND DuraLite suspensions are rated at 22,400 pounds (358,400 kg) GAWR (Gross Axle Weight Rating) with one, two or three leaf springs and 24,000 lbs. (384,000 kg) GAWR with heavy duty leaf springs. (SAF-HOLLAND does not supply springs.)

For leaf spring selection and mounting height information, refer to appropriate Table in Section 12. Check that adequate clearance is provided to all components of the trailer, including but not limited to tires, brakes and air lines.

IMPORTANT: The suspension hangers must be on the same centers as the spring seats and springs, within the tolerances shown. The springs must be square with the axles and located the same distance from the axle centerline within the tolerances shown.

IMPORTANT: Improperly installed suspension components can lead to the following trailer problems: trailer lean, improper tracking, premature tire wear and shortened suspension life.

CAUTION Failure to correctly install suspension components will reduce suspension performance which, if not avoided, could result in premature suspension failure.

3. Welding Standards

3.1 Scope

Your SAF-HOLLAND suspension has been designed to be installed onto a trailer frame. When welding the suspension observe the requirements below. Customers may not weld on an SAF-HOLLAND suspension without our prior approval, including the application of the American Welding Society standards by SAF-HOLLAND engineering. This specification applies to all components supplied by SAF-HOLLAND, and its products. The customer assumes all responsibility for weld integrity if weld material and procedure differ from those listed below.

3.2 Material

Frame attachment components made from low carbon or high strength alloy steel are to be welded with AWS filler metal specification AWS A5.18, filler metal classification ER-70S-3, ER-70S-6 or equivalent unless specified on the installation drawing.

NOTE: Any substitution for filler material from the above standard must comply, as a minimum, with the following mechanical properties:

- Tensile Strength - 72k psi (496 MPa)
- Yield Strength - 60k psi (414 MPa) o F (-17.7o C)
- % Elongation - 22%

The recommended welding gas for gas metal arc welding (GMAW) is 90% Argon / 10% CO₂. If a different gas is used, welds must comply with penetration requirements in shown below. Where the installation drawing specifies different than above, the drawing shall prevail.

3.3 Procedures

Tack welds used for positioning components are to be located in the center of the final weld, where practical. Tack weld should be completely fused to the finish weld. DO NOT break arc at the end of the weld. Back up all finish welds at least 1/2" (12 mm) or a sufficient amount to prevent craters at the end of the weld. Where weld is shown to go around corners, it is assumed the corner represents a stress concentration area. DO NOT start or stop weld within 1" (25 mm) of the corner. Particular care should be taken to prevent undercutting in this area.

3.4 Workmanship

It is the responsibility of the Customer to provide good workmanship when attaching components to the frame structure.

3.5 Weld Size

If weld size is not specified, the effective throat of the weld must be a minimum of the thinnest material being welded (**Figure 1**).

Figure 1

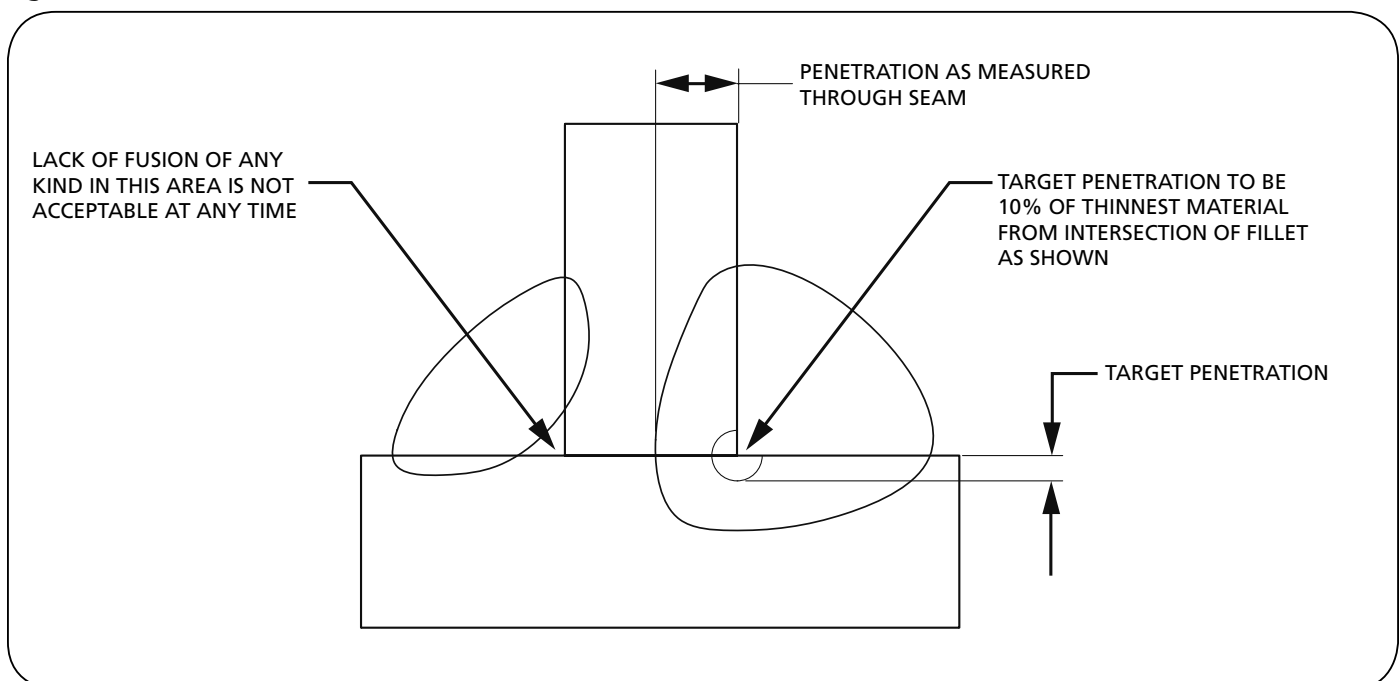

4. Trailer Frame Hanger Brackets Location – All Styles

The DuraLite suspension is available in five hanger bracket mounting styles: under mount, flange mount, straddle mount, side mount and straddle/under mount. The DuraLite suspension may be used as a single axle, tandem axle or triple axle. The base suspension is the single axle – adding a multi-axle conversion kit converts the single axle to a tandem and a second multi-axle kit will make a triple axle suspension. The DuraLite suspension is available in overslung (axle below the spring) or underslung (axle above the spring) configuration.

NOTE: The following instructions for hanger bracket location apply to all hanger bracket styles listed above. After the hanger brackets have been properly located and tack welded to the trailer frame, proceed to the appropriate bracket type in this section for installation instructions.

1. Measure and mark hanger bracket locations on bottom of trailer frame referencing the dimensions provided for single axle (**Figure 2a**), tandem axle (**Figure 2b**) or triple axle (**Figure 2c**).

- Hanger spacing is always measured from center line to center line of hanger (**Figure 2**).
- The front and rear hangers are always located an equal distance from the center hanger and should not vary from dimension shown more than plus or minus 1/16" (1 mm).
- Hangers must be located on both sides of sub-frame in exactly the same distances from front and rear of trailer frame.
- Hangers on one side of sub-frame must not be in front of or behind corresponding hangers on other side of sub-frame by more than plus or minus 1/16" (1 mm).

IMPORTANT: Frame surface where hanger brackets are to be attached must be clean and free of any surface rust. Use wire brush or light-duty grinder to clean surface.

2. Position hanger brackets on frame according to location marks determined in Step 1. Position and tack weld all hangers in position and double check dimensions before completing welding of hangers (**Figure 2a, 2b and 2c**).

IMPORTANT: Hangers must be mounted in proper alignment with one another and must not be cocked or tilted in respect to the sub frame mounting surface.

Figure 2

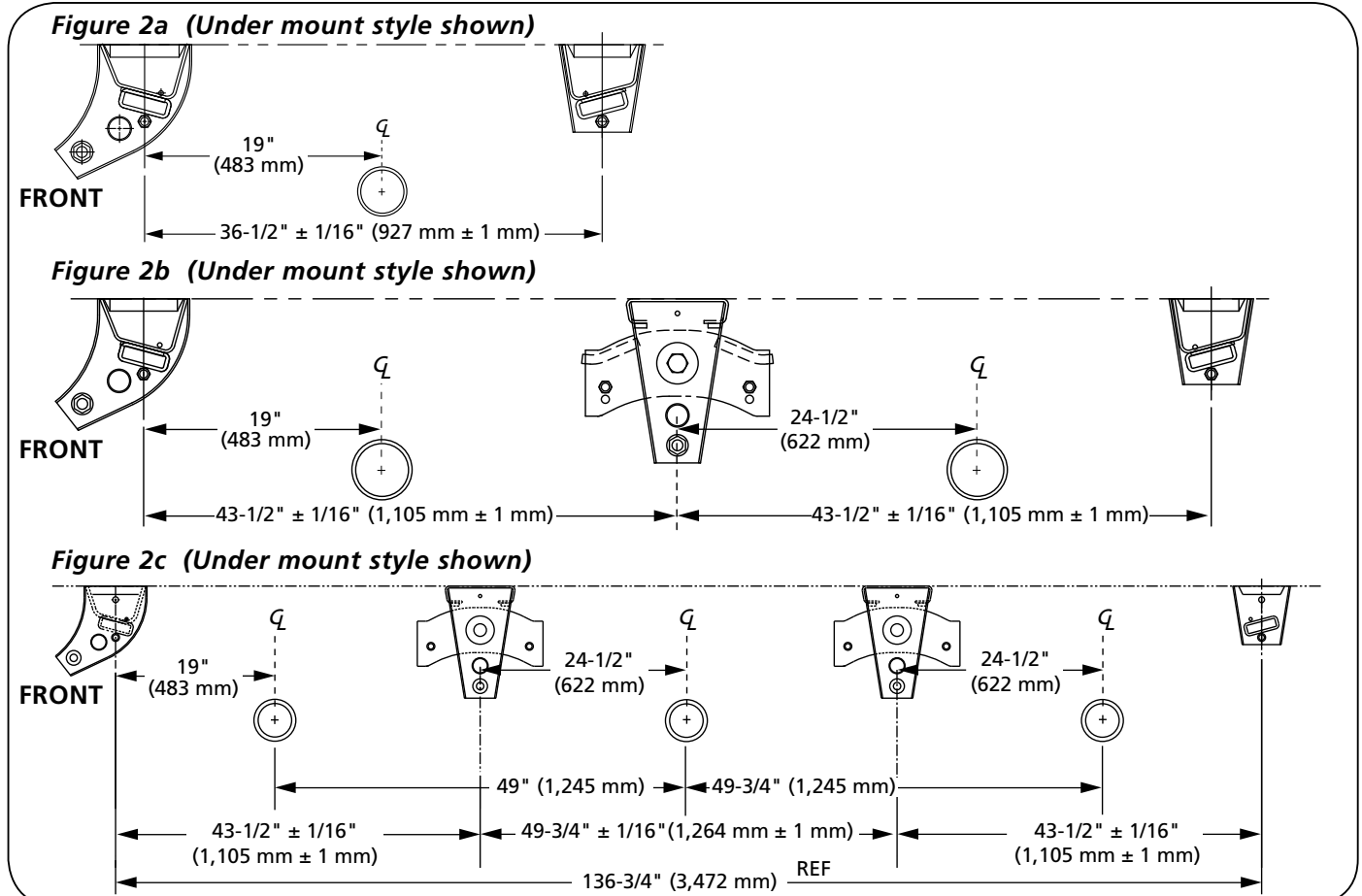

Under Mount Hanger Brackets Installation

NOTE: For flange, straddle, sidemount or straddle/under style brackets installation, refer to specific instructions later in this section.

IMPORTANT: The under mount style hanger brackets must be located on the trailer frame to match the axle spring center (**Figure 3**).

1. Install a 1-1/4" schedule 40 pipe or 1.66 O.D. x .109 standard mechanical tubing through the front and center hangers. The pipe brace should be 6" (152 mm) longer than the spring

centers that will provide approximately 3" (76 mm) of pipe to protrude equally on each side. Tack weld the pipe brace in place (**Figure 3**).

2. Add 3/16" (4 mm) minimum diagonal braces between the front, center and rear hangers and the frame of the trailer (**Figure 3**).
3. Re-verify position of hanger and pipe bracket.
4. Weld the suspension hangers in place (**Figures 4a, 4b and 4c**). Weld the pipe braces and diagonal braces in place (**Figure 3**).

Figure 3

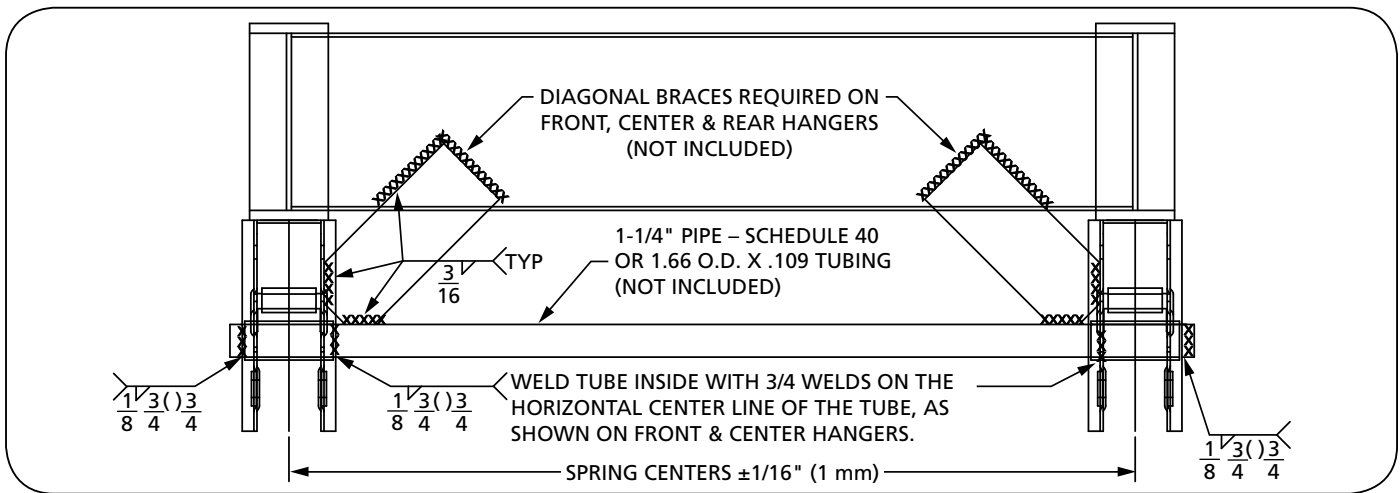
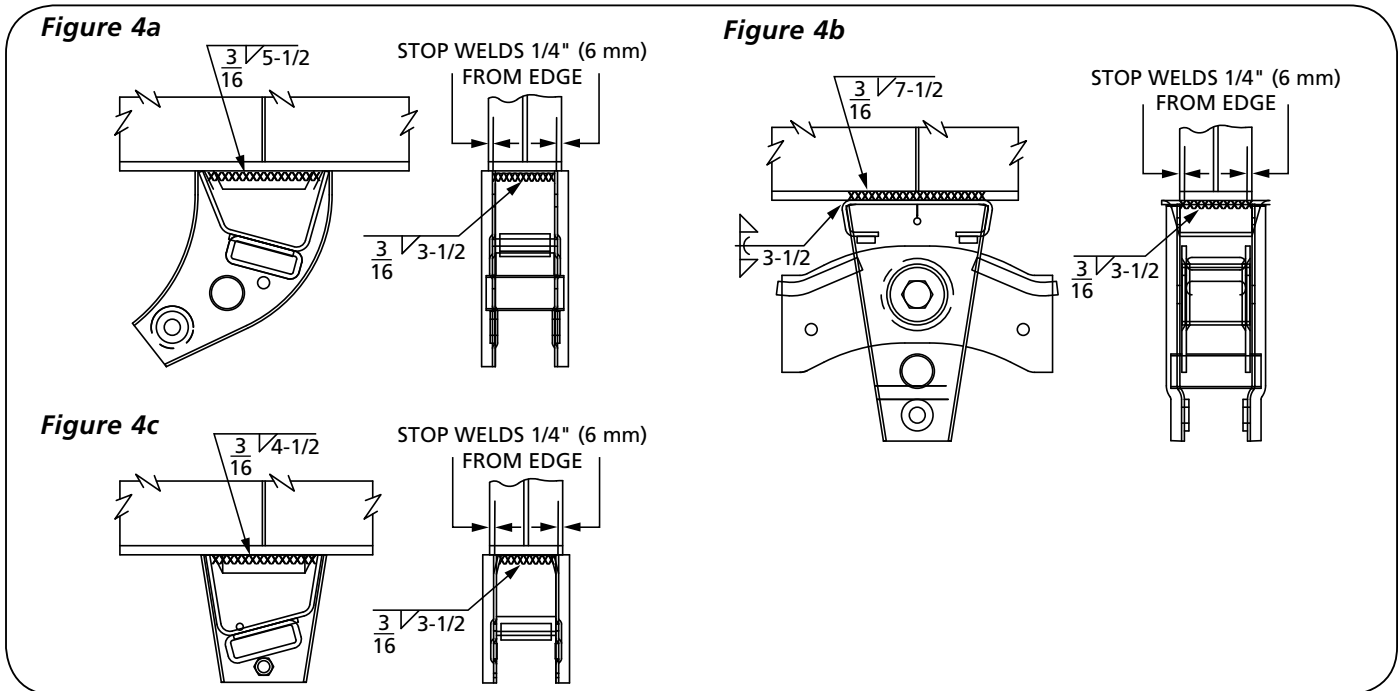

Figure 4



Flange Hanger Brackets Installation

1. Install a 1-1/4" schedule 40 pipe or 1.66 O.D. x .109 standard mechanical tubing through the front and center hangers. The pipe brace should be 6" (152 mm) longer than the spring centers that will provide approximately 3" (76 mm) of pipe to protrude equally on each side. Tack weld the pipe brace in place (**Figure 5**).
2. Add 3/16" (4 mm) minimum diagonal braces between the front, center and rear hangers and the frame of the trailer (**Figure 5**).
3. Re-verify position of hanger and pipe bracket.
4. Weld the suspension hangers in place (**Figures 6a, 6b and 6c**). Weld the pipe braces and diagonal braces in place (**Figure 5**).

Figure 5

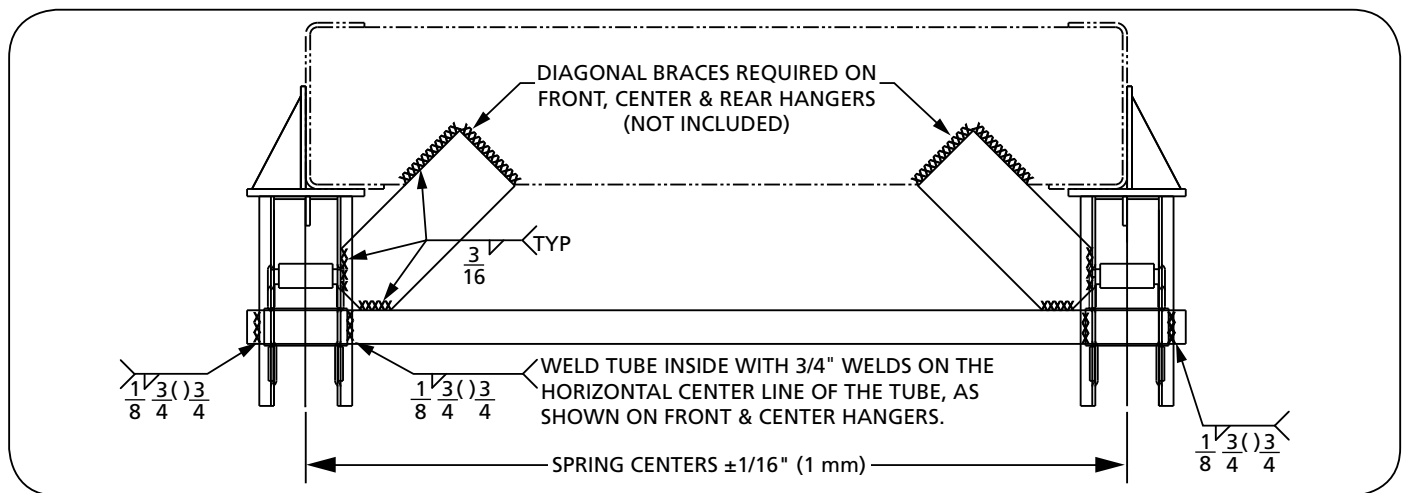
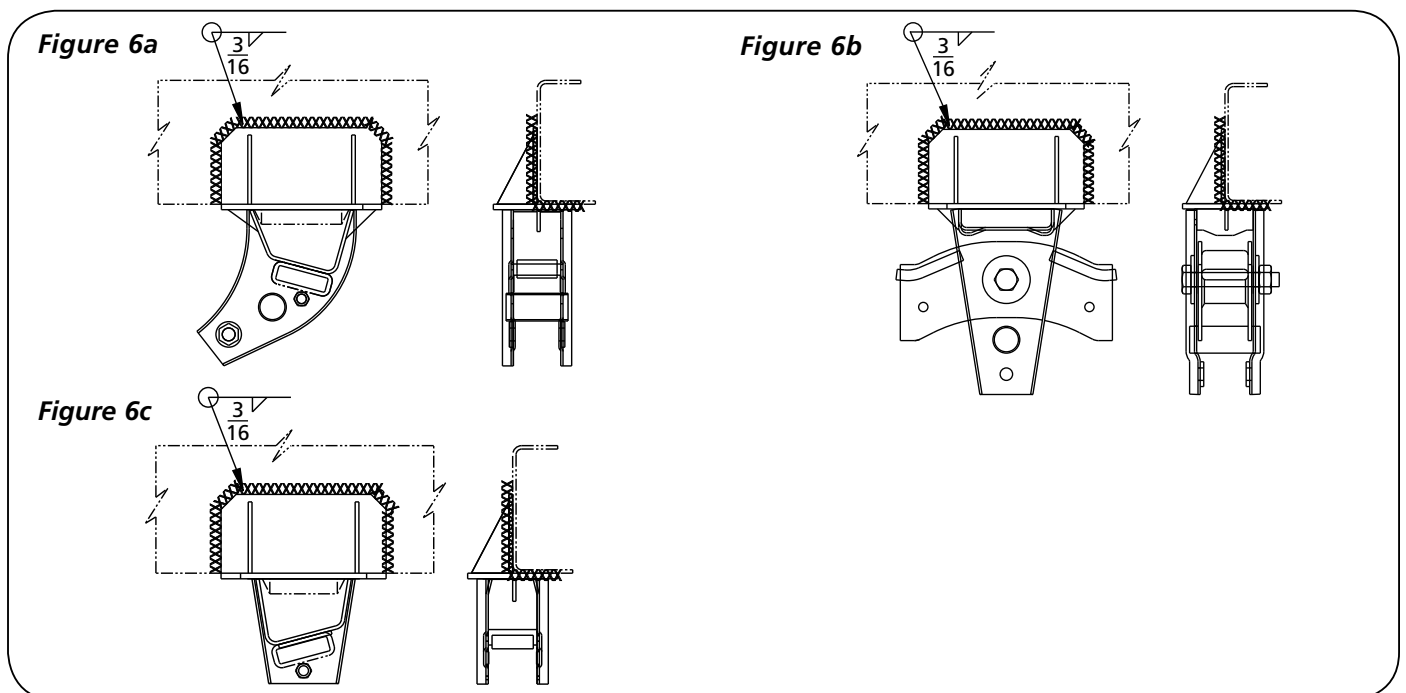

Figure 6



Straddle Hanger Brackets Installation

1. Install a 1-1/4" schedule 40 pipe or 1.66 O.D. x .109 standard mechanical tubing through the front and center hangers. The pipe brace should be 6" (152 mm) longer than the spring centers that will provide approximately 3" (76 mm) of pipe to protrude equally on each side. Tack weld the pipe brace in place (**Figure 7**).
2. Re-verify position of hanger and pipe bracket.
3. Weld the suspension hangers in place (**Figures 8a, 8b and 8c**). Weld the pipe braces in place (**Figure 7**).

Figure 7

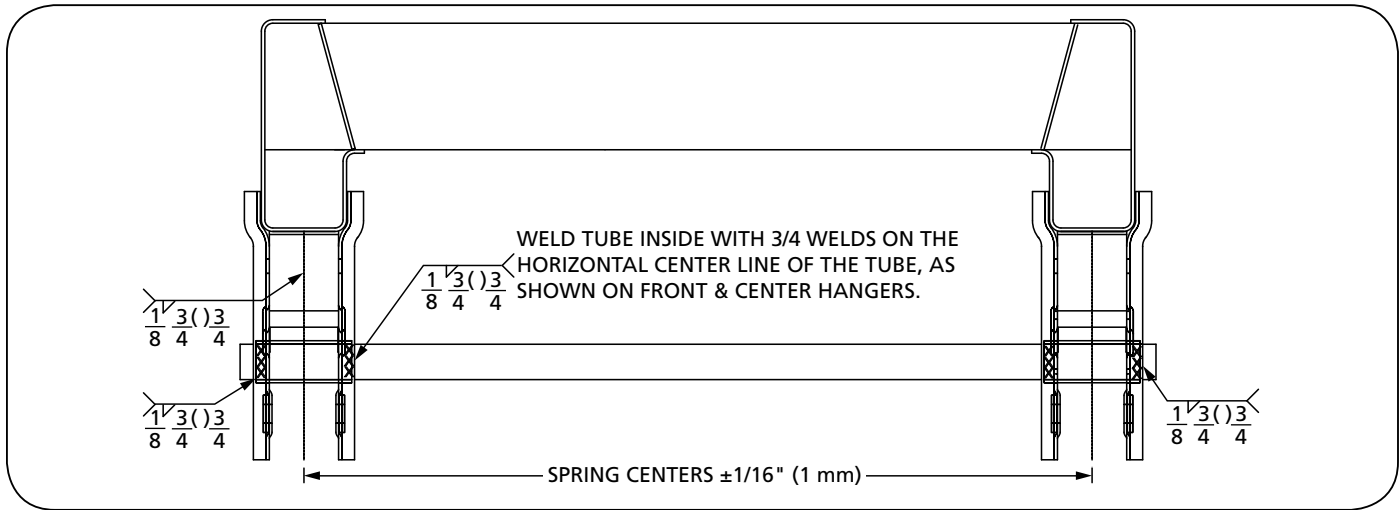
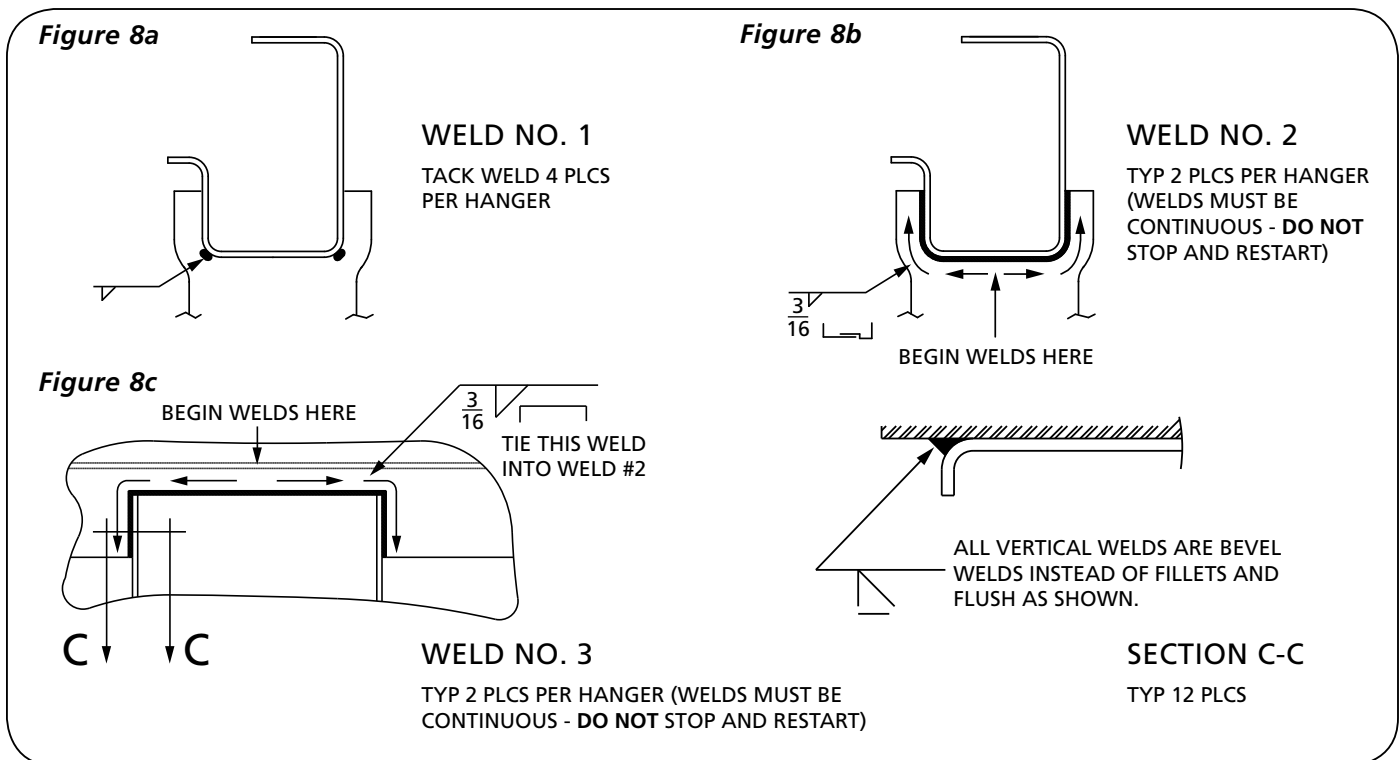

Figure 8



Side Mount

1. Install a 1-1/4" schedule 40 pipe or 1.66 O.D. x .109 standard mechanical tubing through the front and center hangers. The pipe brace should be 6" (152 mm) longer than the spring centers that will provide approximately 3" (76 mm) of pipe to protrude equally on each side. Tack weld the pipe brace in place (**Figure 9**).
2. Re-verify position of hanger and pipe bracket.
3. Weld the suspension hangers in place (**Figures 10a, 10b and 10c**). Weld the pipe braces in place (**Figure 9**).

Figure 9

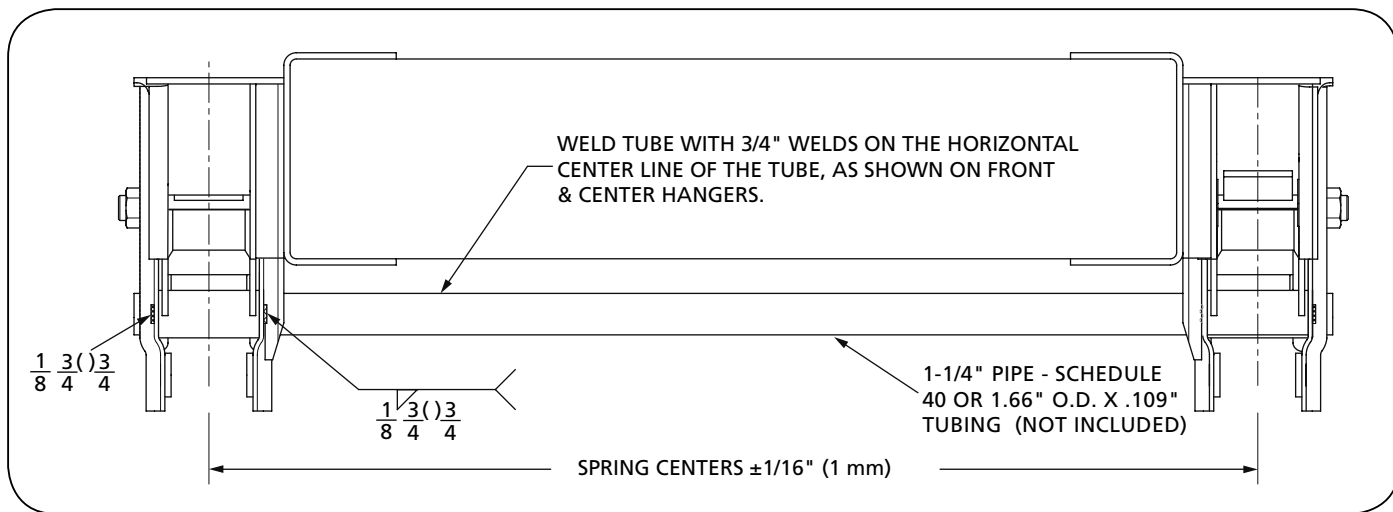
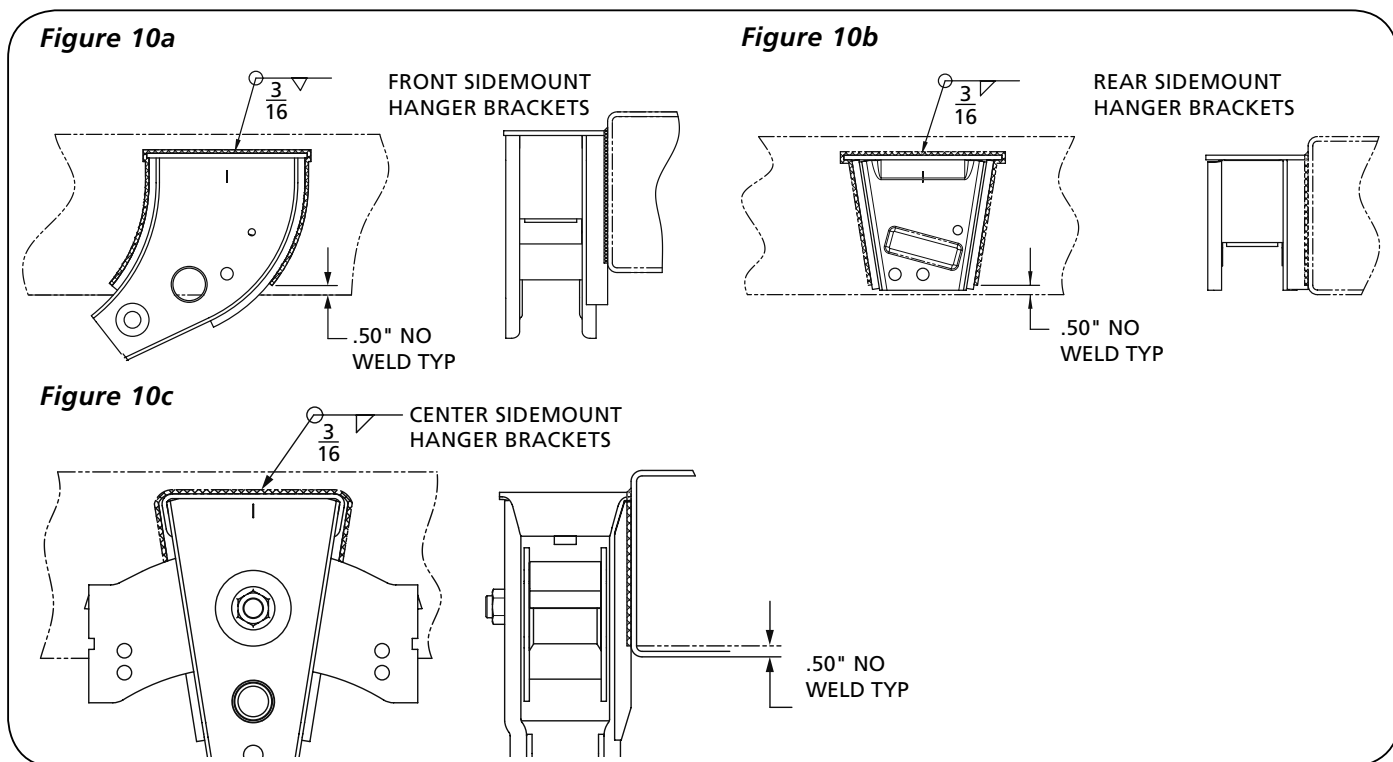

Figure 10



Straddle/Under Mount

1. Install 3/16" thick angle braces at Front, Center, and Rear hangers. Brace should be at approximately a 45° angle and extend at least to the mid-point of the hanger. Tack weld the braces in place. **(Figure 11).**
2. Re-verify position of hanger and angle braces.
3. Weld the suspension hanger brackets in place **(Figures 12a, and 12b).** Weld the angle braces in place **(Figure 11).**

Figure 11

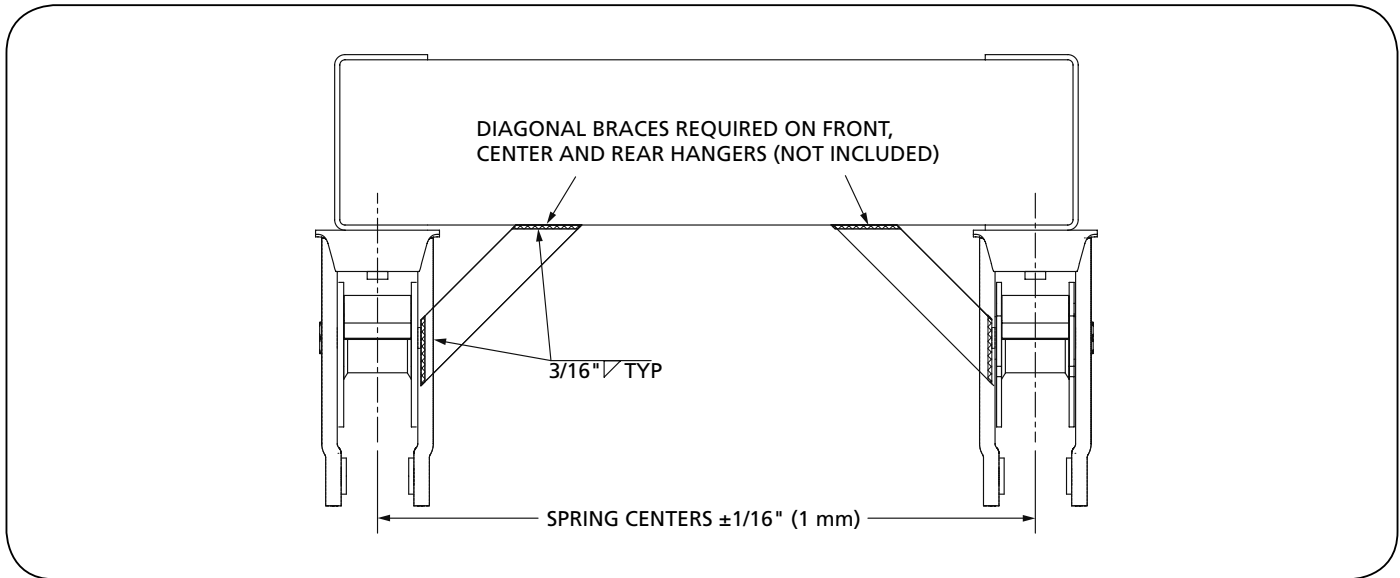
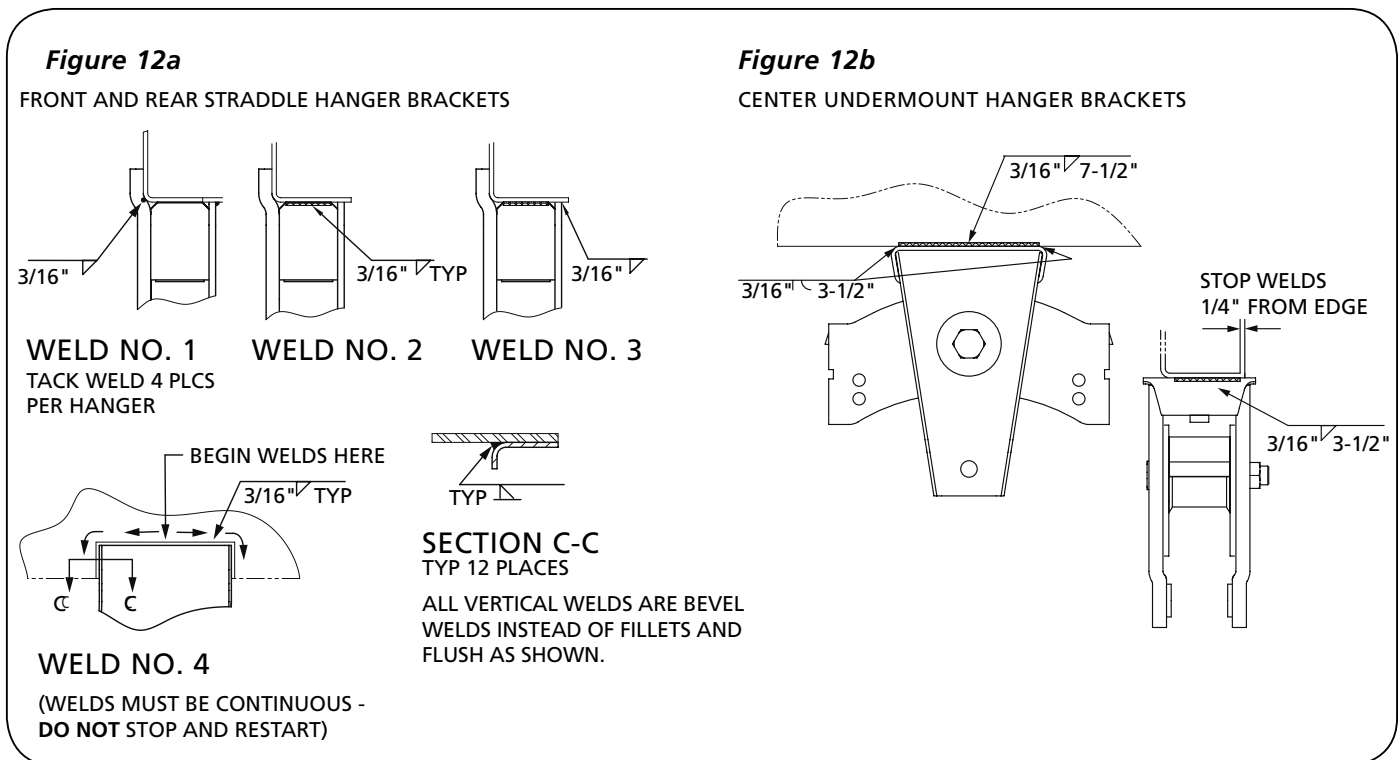

Figure 12



5. Weld Axle Seats To Axles Instructions

IMPORTANT: The axle seats and bottom plates that are welded to the axle are compatible with all low hydrogen welding processes suitable for welding to steel axles.

Overslung Axle Style

1. The axle seats should be located on the spring centers within .06" (1 mm). The axle seats should be the same distance from the center of the axle within .03" (.7 mm). The camshaft should be oriented per the axle manufacturer's specification.

NOTE: When the cams are forward, the cam must be below the horizontal centerline when axle seats of 2" (51 mm) or shorter height are used.

2. Clamp the axle seats and bottom plates to the axle. The axle **MUST** contact the axle seat and bottom plate at the top and bottom center of the adapters or contact at least two points no more than 1-1/2" (38 mm) from center of the axle (**Figure 13**).
3. Verify correct connection. Using a .006" (0.15 mm) feeler gage be sure it is **NOT** able to slide between axle and spring seat or bottom plate more than 1/4" (6 mm) in contact area (**Figures 14a and 14b**). If a greater gap is present, these parts may be clamped to the axle or adjusted to fit by grinding the axle seat.

⚠ WARNING Failure to maintain proper clearance between the axle and parts welded to it may result in premature weld failure, which if not avoided, could result in death or serious injury.

4. Following the axle manufacturer's recommendations, weld the axle seats and bottom plates to the axles (**Figures 14a and 14b**).

Figure 14a

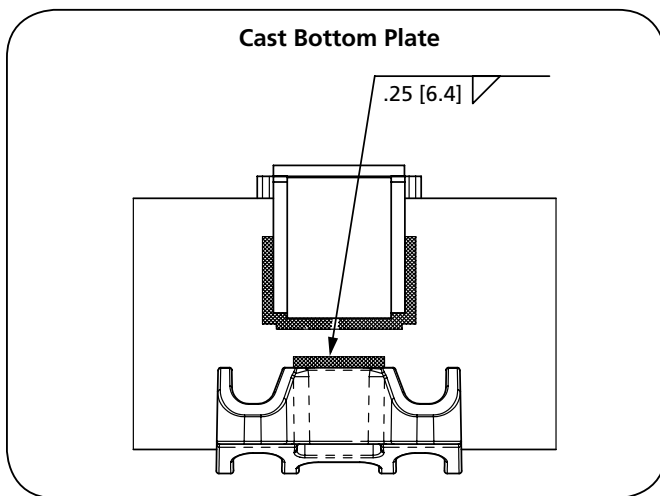

Figure 13

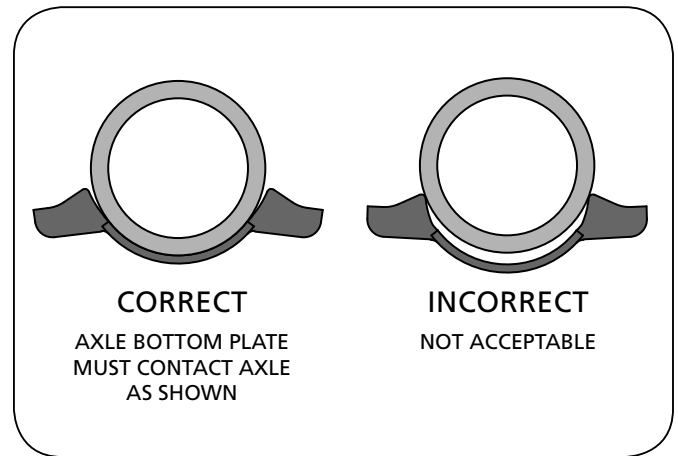
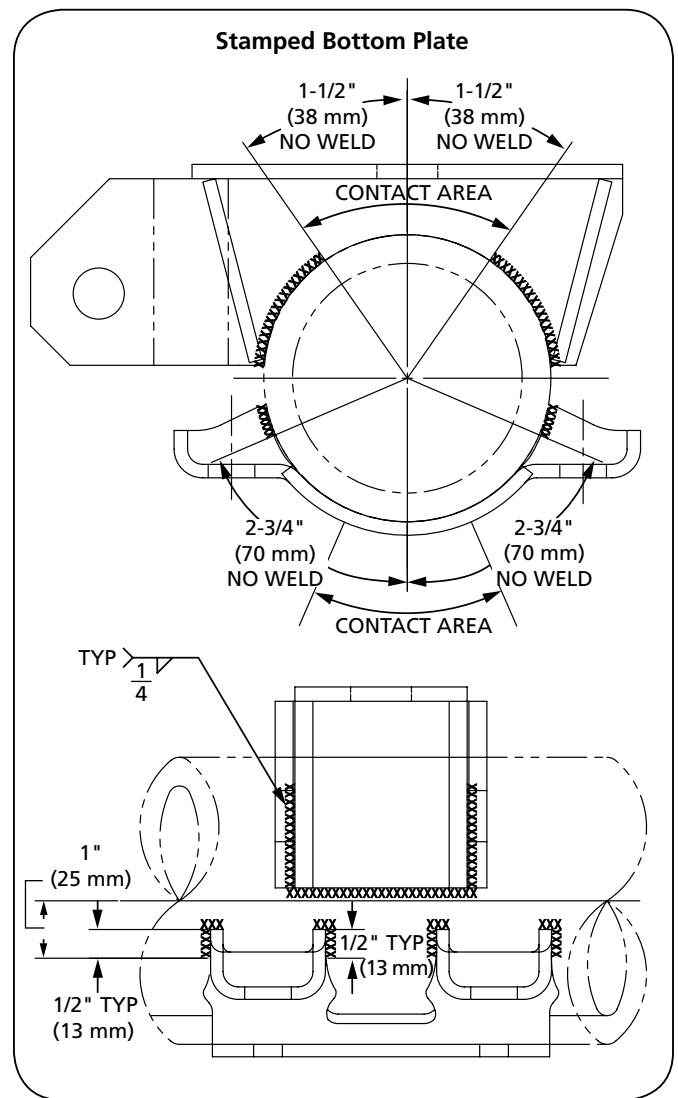

Figure 14b



Underslung Axle Style

IMPORTANT: The axle seats and bottom plates that are welded to the axle are compatible with all low hydrogen welding processes suitable for welding to steel axles.

1. The axle seats should be located on the spring centers within .06" (1 mm). The axle seats should be the same distance from the center of the axle within .03" (.7 mm). The camshaft should be oriented per the axle manufacturer's specification.

NOTE: When the cams are forward, the cam must be below the horizontal centerline when axle seats of 2" (51 mm) or shorter height are used.

2. Clamp the axle seats and bottom plates to the axle. The axle **MUST** contact the axle seat and bottom plate at the top and bottom center of the adapters or contact at least two points no more than 1-1/2" (38 mm) from center of the axle (**Figure 15**).
3. Verify correct connection. Using a .006" (0.15 mm) feeler gage be sure it is **NOT** able to slide between axle and spring seat or bottom plate more than 1/4" (6 mm) in contact area. If a greater gap is present, these parts may be clamped to the axle or adjusted to fit by grinding the axle seat.

WARNING Failure to maintain tire clearance between tires and the nearest point of contact on the suspension or vehicle could cause fire or loss of vehicle control which, if not avoided, could result in death or serious injury.

4. Following the axle manufacturer's recommendations, weld the axle seats and bottom plates to the axles (**Figure 16**).

Figure 15

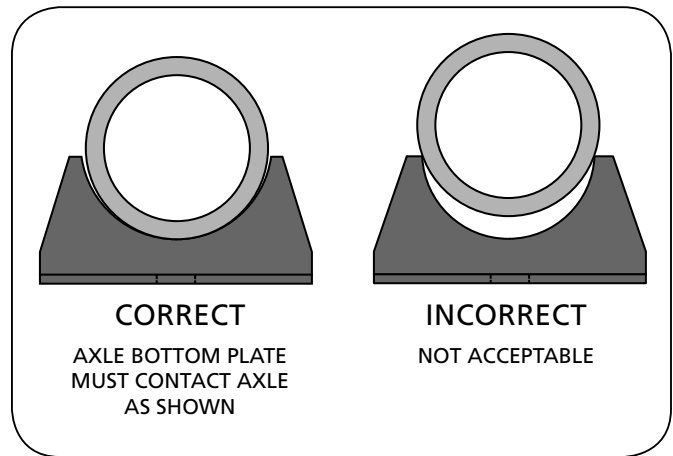
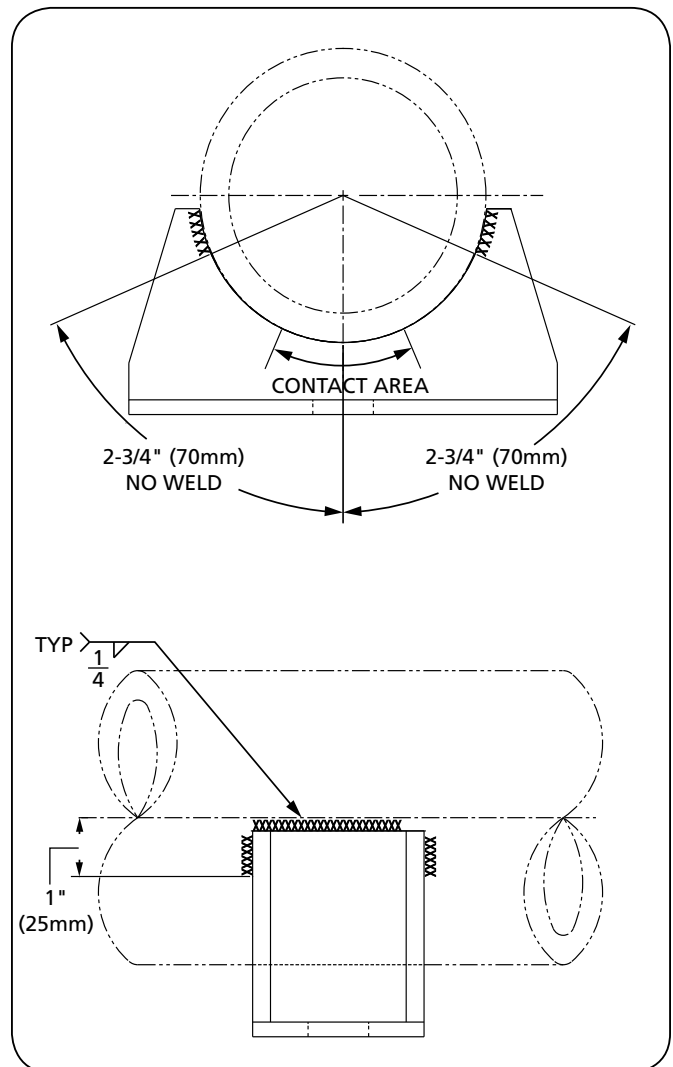

Figure 16



6. Leaf Springs and Torque Arms Assembly

Overslung Axle Style

NOTE: It is recommended that fasteners be installed with the nuts on the outside (closest to tires).

NOTE: Torque specifications are with clean lubricated/coated threads. All new SAF-HOLLAND fasteners come pre-coated from the factory.

IMPORTANT: The use of special lubricants with friction modifiers, such as Anti-Seize or Never-Seize, without written approval from SAF-HOLLAND Engineering, will void warranty and could lead to over torquing of fasteners or other component issues.

Torque Arms and Springs Installation

1. Position the supplied spring liner on top of the springs and set it on top of the axle spring seat (**Figure 17**). Place the top plate on top of the spring.
2. Install the springs on the axles with the appropriate U-bolts, nuts and washers. The U-bolts will fit into the detents stamped into the top plate (**Figure 17**).

IMPORTANT: On tandem axle suspensions the big hook end of the spring should be arranged to fit in the equalizer (**Figure 18a**). On single axle suspensions it should point to the rear (**Figure 18**). Arrange the springs so that they are on the correct centers ± 0.03 " (1 mm) and perpendicular to the axle.

3. Tighten the U-bolts to 275-300 ft.-lbs. (373-407 N•m) of torque using an alternating pattern (**Figure 17a**). Check the spring centers and adjust if necessary.

CAUTION DO NOT hit steel parts with a steel hammer as parts could break, sending flying steel fragments in any direction creating a hazard which, if not avoided, could result in minor to moderate injury.

4. Install the axles with springs into the suspension hangers. Install the 5/8" spring retainer bolts and spacers in the front and rear hangers, and the equalizer on tandem axles to hold the springs in place. Tighten 5/8" bolts to 35-50 ft.-lbs. (47-68 N•m) (**Figure 18**).

IMPORTANT: DO NOT overtighten as this may damage the spacers.

5. Install the torque arms between the hangers and the spring seats on the axles. It is recommended that the adjustable torque arms be installed on the roadside and the fixed (cast) torque arms be installed on the curbside (**Figure 19**). Install the 7/8" nuts and bolts to secure the torque arms in place and torque to 275-300 ft.-lbs. (373-407 N•m) (**Figure 19**).
6. With the suspension installed, check that there is $1/8" \pm 3/32"$ (3 mm \pm 2 mm) clearance between the springs and the sides of the hangers and that all the springs are contacting the bottoms of the hangers (**Figure 19a**).
7. Position the decal, XL-MS189-01, in clear view on the roadside of the vehicle as close as practical to the suspension.

Figure 17

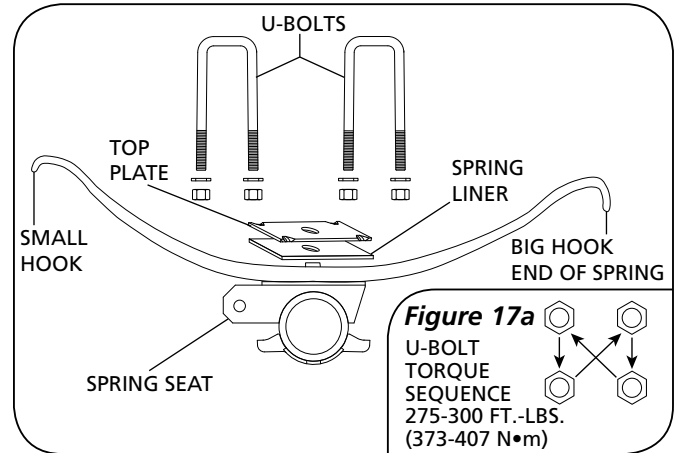

Figure 18

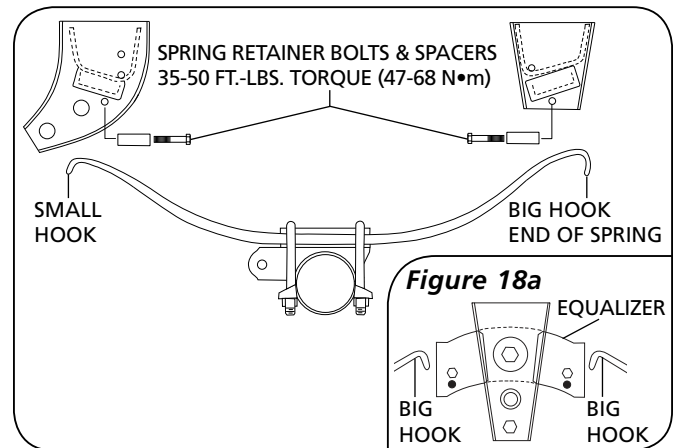
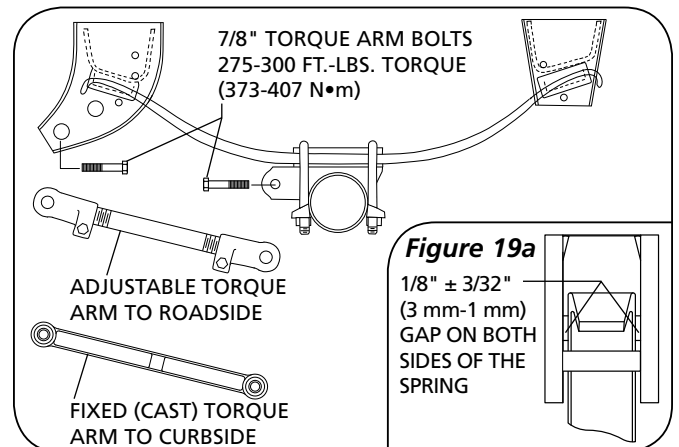

Figure 19



Underslung Axle Style

NOTE: It is recommended that fasteners be installed with the nuts on the outside (closest to tires).

NOTE: Torque specifications are with clean lubricated/coated threads. All new SAF-HOLLAND fasteners come pre-coated from the factory.

Torque Arms and Springs Installation

1. Assemble the springs. Position the supplied spring liner on top of the springs and set it on top of the axle spring seat (**Figure 9**). Place the top plate on top of the spring.
2. Install the springs to the axles with the appropriate U-bolts, nuts and washers.

IMPORTANT: On tandem axle suspensions the big hook end of the spring should be arranged to fit in the equalizer (**Figure 21a**). On single axle suspensions it should point to the rear (**Figure 21**). Arrange the springs so that they are on the correct centers $\pm 0.3"$ (1 mm) and perpendicular to the axle.

3. Tighten the U-bolts to 275-300 ft.-lbs. (373-407 N•m) of torque using an alternating pattern (**Figure 20a**). Check the spring centers and adjust if necessary.

CAUTION DO NOT hit steel parts with a steel hammer as parts could break, sending flying steel fragments in any direction creating a hazard which, if not avoided, could result in minor to moderate injury.

4. Install the axles with springs into the suspension hangers. Install the 5/8" spring retainer bolts and spacers in the front and rear hangers, and the equalizer on tandem axles to hold the springs in place. Tighten 5/8" bolts to 35-50 ft.-lbs. (47.68 N•m) (**Figure 21**).

IMPORTANT: DO NOT overtighten as this may damage the spacers.

5. Install the torque arms between the hangers and the bottom plates on the axles. It is recommended that the adjustable torque arms be installed on the roadside and the fixed torque arms be installed on the curbside (**Figure 22**). Install the 7/8" nuts and bolts to secure the torque arms in place and torque to 275-300 ft.-lbs. (373-407 N•m) (**Figure 22**).
6. With the suspension installed, check that there is $1/8" \pm 3/32"$ (3 mm \pm 2 mm) clearance between the springs and the sides of the hangers and that all the springs are contacting the bottoms of the hangers (**Figure 22a**).
7. Position the decal, XL-MS189-01 in clear view on the roadside of the vehicle as close as practical to the suspension.

Figure 20

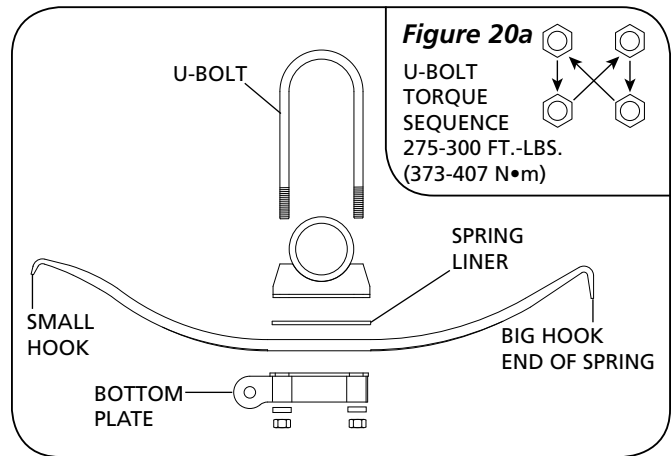

Figure 21

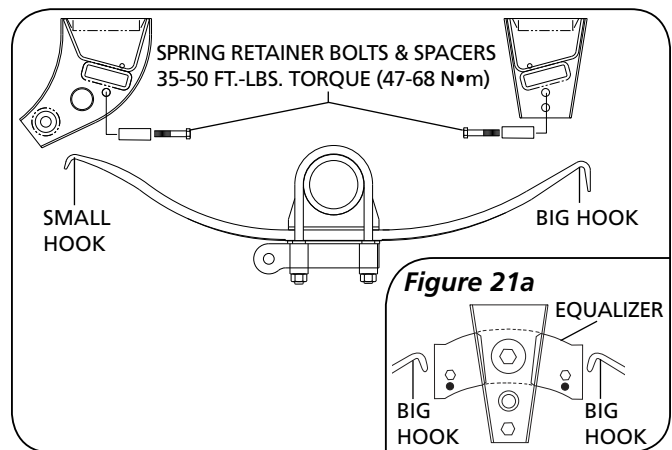
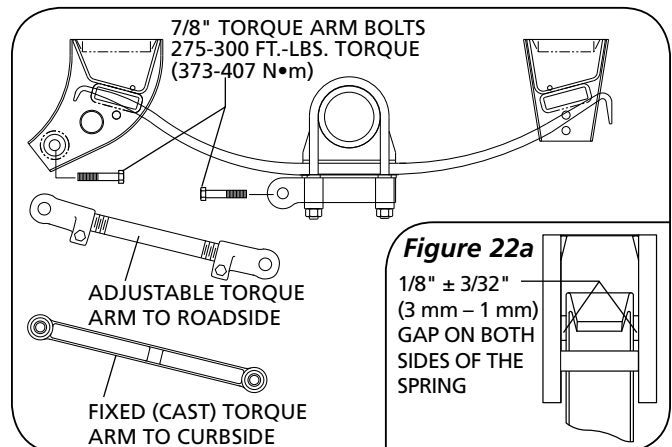

Figure 22



7. Axle Alignment

IMPORTANT: Axle alignment should always be done while the trailer is empty.

1. Pull the trailer in a straight line for a sufficient distance to ensure there are no binds in the suspension.
2. Engage the trailer park brakes.
3. Check that the ends of the springs are contacting the bottom wear pads in all hangers.
4. Loosen the 5/8" clamp bolts on the adjustable torque arms.
5. Disengage the trailer parking brakes and ensure the trailer is empty.
6. Manually measure or use an optical device specifically designed for alignment measuring to determine the following:
 - a. Measure the distance from the king pin to the centerline of the front axle spindles. It is recommended that spindle extensions be utilized.
 - b. Dimensions A and B (**Figure 23**) must be equal to within 1/8" (3 mm).
 - c. Measure the distance from the centerline of the front axle spindles to the centerline of the rear axle spindles.
 - d. Dimensions C and D (**Figure 23**) must be equal to within 1/16" (1 mm).
7. Tighten the clamp bolts on the adjustable torque arm to 85-95 ft.-lbs. (108-129 N•m) of torque.

8. Final Inspection

1. Verify that the hanger brackets to mounting sub-frame and axle seat welds have been completed per specifications, refer to Section 4.
2. Check all suspension fastener connections for proper torque settings (**Figures 25**).
3. Check adjustable torque arm clamp nuts to be certain that 85-95 ft.-lbs. (115-129 N•m) torque is maintained.
4. Check for proper suspension mounting height.
5. Check for proper 4-1/2" (114 mm) vertical tire clearance (**Figure 24**).
6. Verify that the front axle alignment does not exceed a maximum variation of 1/8" (3 mm) kingpin to front axle and a maximum variation of 1/16" (1 mm) axle to axle on any additional axles (**Figure 15**).

9. Operating Recommendations

1. Observe the operating recommendation of the trailer manufacturer for off-road operation of the installed axles, refer to Section 1.

Figure 23

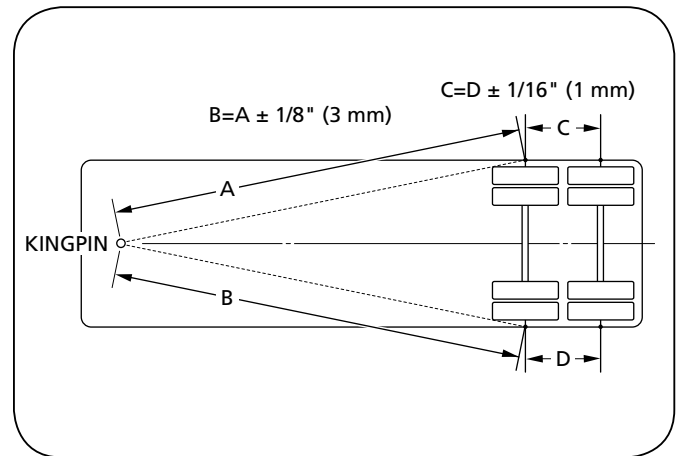
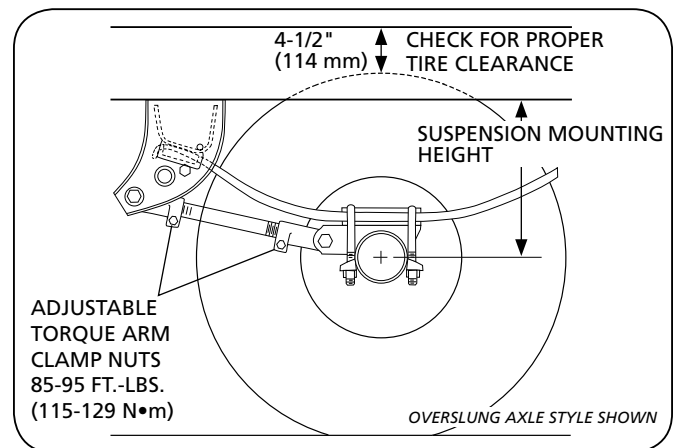

Figure 24



10. Routine Maintenance and Daily Inspection

DuraLite® suspensions, by design, require a minimum of maintenance. However, suspensions require periodic checks to be certain of continued trouble free performance.

- Daily or before each trip, check the suspension to be sure it is fully operational.
- Inspect all decals to ensure they are clearly legible and intact. Clean with a terry cloth towel, soap and water.
- After an initial break-in period of 1,000 miles (1,609 km), re-check the trailer alignment and correct as necessary.

10.1 Routine Physical/Visual Inspections

All fasteners, torque arms, springs, hangers and welds should be visually inspected at 25,000 miles (40233 km) intervals and at all inspections for excessive wear, deformation and structural soundness.

IMPORTANT: A schedule for physical and visual inspections should be established by the operator based on severity of operation or damage to the vehicle could occur.

IMPORTANT: During each pretrip and safety inspection of the vehicle, a visual inspection of the suspension should be done or damage to the vehicle could occur.

NOTE: Failure to maintain proper fastener torque values could result in suspension component damage and loss of vehicle control which, if not avoided, could result in death or serious injury.

IMPORTANT: The use of special lubricants with friction modifiers, such as Anti-Seize or Never-Seize, without written approval from SAF-HOLLAND Engineering, will void warranty and could lead to over torquing of fasteners or other component issues.

Visually check for:

- Loose, damaged or missing fasteners. Repair or replace as needed.



Loose, damaged, or missing fasteners can cause loss of vehicle control which, if not avoided, could result in death or serious injury.

- Cracked parts or welds.
- Check 3/4"-16 U-bolt nuts to be certain that 275-300 ft.-lbs. (373-407 N•m) torque is maintained.
- Check 1-14" equalizer bolt to be certain that 450-500 ft.-lbs. (610-678 N•m) torque is maintained
- Check 7/8"-14 torque arm bolts to be certain that 275-300 ft.-lbs. (373-407 N•m) torque is maintained.
- Check adjustable torque arm clamp nuts to be certain that 85-95 ft.-lbs. (115-129 N•m) torque is maintained.
- Check spring retainer bolts to be certain that 35-50 ft.-lbs. (47-68 N•m) torque is maintained.

Figure 25

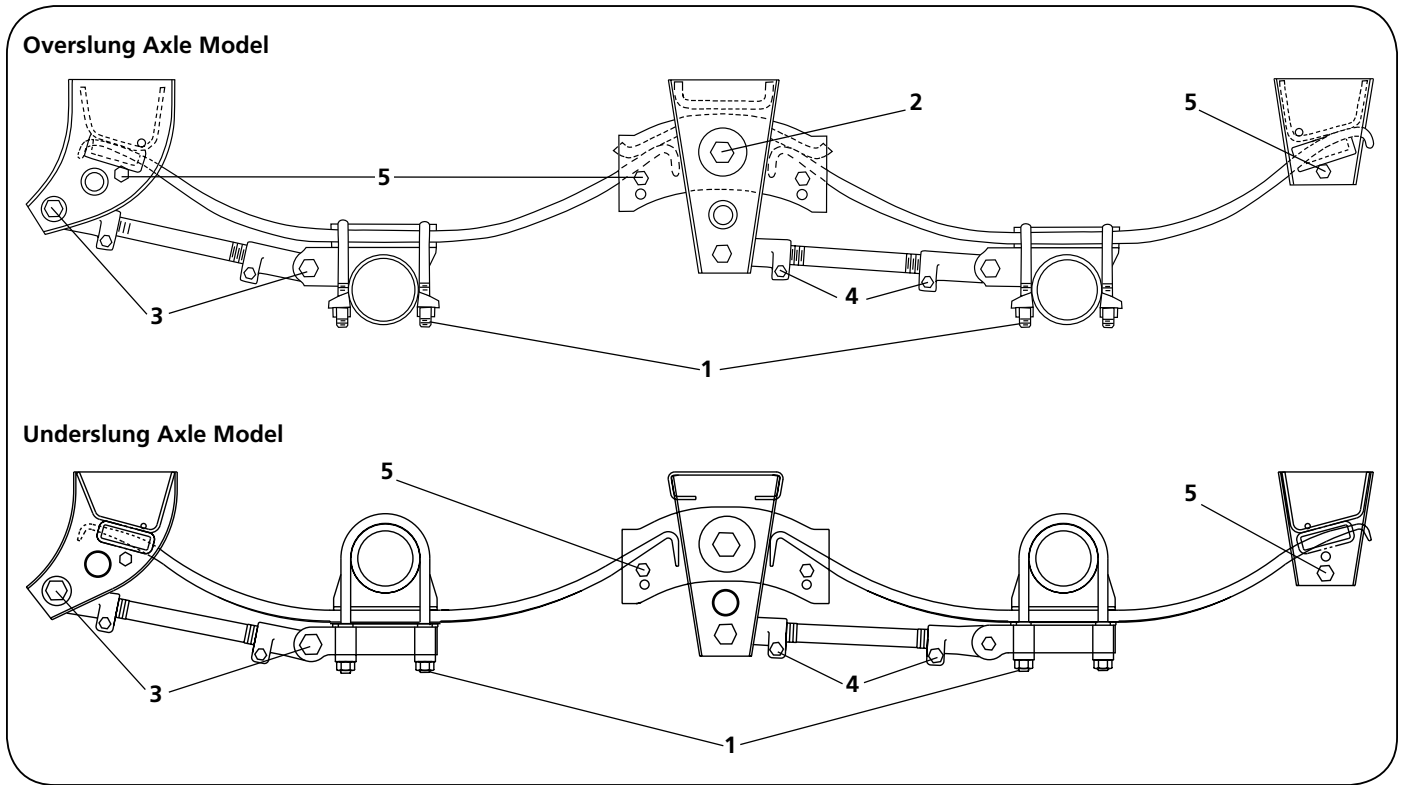

11. Leaf Spring Selection

⚠ WARNING Failure to maintain tire clearance between tires and the nearest point of contact on the suspension or vehicle could cause fire or loss of vehicle control which, if not avoided, could result in death or serious injury.

SAF-HOLLAND DuraLite suspensions are rated up to 25,000 lbs. (11,340 kg) GAWR with proper springs, axles and brakes. The following widely available SAF-HOLLAND leaf springs are suitable for use with DuraLite suspensions:

SPRING TYPE	SINGLE LEAF	TWO LEAF	THREE LEAF	THREE LEAF HD
Low Arch	SP0363	SP0326	SP0356	SP9365-01
Medium Arch	–	SP0325	SP0355	–
High Arch**	SP0360*	SP0324	SP0354	SP0365

* Not approved for single axle applications.

** SAF-HOLLAND does NOT recommend use of high arch springs in single axle applications.

IMPORTANT: It is the installer’s responsibility to select the correct mounting height. There should be 4-1/2" (114 mm) of vertical tire clearance with an unloaded vehicle. In addition, clearance must be provided at the side, front, and rear of the tires to prevent tire contact during suspension movement. The mounting heights, shown below, are nominal values and may vary due to variations in the leaf springs and other components.





SAF-HOLLAND Group



From fifth wheel rebuild kits to suspension bushing repair kits, SAF-HOLLAND Original Parts are the same quality components used in the original component assembly.

SAF-HOLLAND Original Parts are tested and designed to provide maximum performance and durability. Will-fits, look-a likes or, worse yet, counterfeit parts will only limit the performance potential and could possibly void SAF-HOLLAND's warranty. Always be sure to spec SAF-HOLLAND Original Parts when servicing your SAF-HOLLAND product.

SAF-HOLLAND USA • 888.396.6501 • Fax 800.356.3929
www.safholland.us

SAF-HOLLAND CANADA • 519.537.3494 • Fax 800.565.7753
WESTERN CANADA • 604.574.7491 • Fax 604.574.0244
www.safholland.ca

SAF-HOLLAND MEXICO • 52.55.5362.8743 • Fax 52.55.5362.8743
www.safholland.com.mx

info@safholland.com