

CBX Tandem and Tridem

Heavy Duty Air Suspension Slider Solutions for on/off Highway Van and Reefer Trailers



*Featuring Haldex
Calipers and Actuators*



CBX50

Air Suspension Slider Axle Systems

The SAF CBX50 offers a 50,000 lb. capacity tandem slider air suspension featuring both SAF drum and disc brake technology. Designed with the robustness necessary for hauling increased capacities on secondary and unpaved highways the CBX50 delivers a lightweight slider solution for on/off highway applications.

Engineered tough with a sub-frame that features six crossmembers for heavy-duty structural rigidity.

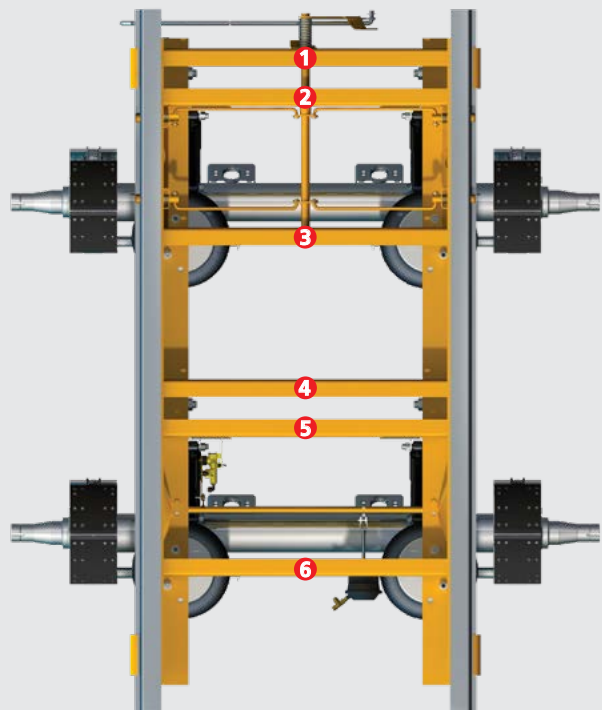

SIX TOTAL CROSSMEMBERS
FOR HEAVY-DUTY DURABILITY

QWIK Release™ Pin Pull

This patented system makes slider adjustment safe and efficient. With 20% less pulling effort than competitive models. One person can easily reposition the slider. This design also alleviates bound-up pin problems.

Swing Align™

The fastest and most convenient axle alignment system in the industry. No replacement parts or disassembly is required. Axle alignment adjustment is made directly by the lead screw, requires less than 250 ft. lbs. of torque to adjust.



Multi-Functional Pivot Bushing

A robust bushing with its exterior void design limits the twisting movement that could lead to premature bushing and tire wear.

Robust Slider Sub-Frame

Constructed with 80 KSI yield material and designed with two additional crossmembers, the CBX50 is the most robust and structurally rigid 50K slider on the market.

PosiLok™

Eliminates dock walk and squat. Creates a stable and safe loading and unloading operation.

OPTIONAL P89 Series AIR DISC BRAKES

Two Model Choices to Meet Your Fleet's Specific Needs

The P89 model at a price point that makes sense for fleets of any size. And, the P89 Plus for premium performance. Disc brakes simply provide better performance than drum brakes. They stop shorter for increased safety and reduced maintenance for lower total cost of ownership.

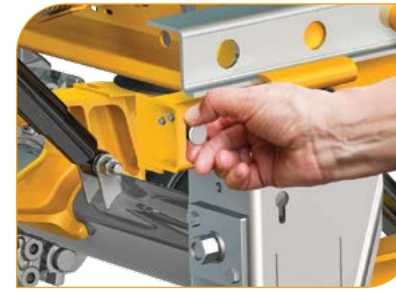

Optional Air Release

A pin-pull system that is simple and efficient. The air release design is compact, durable, and allows easy manual operation in the event of an air-down situation.

Lightweight Cast Steel Trailing Arm Design

Rated for 25,000 lb. capacity per axle for carrying heavier loads, the CBX50 is designed with our proven air suspension cast steel trailing arms

Optional Upper Body Rails

Roll formed body rails are manufactured from high strength 80,000KSI steel.



Air Springs

Capacity enhanced to meet on/off highway application demands. TOFC compliant with a standard pneumatic dump valve.

50,000 lbs.
CAPACITY



Haldex Spring Brake Actuators

feature the premium LifeSeal+ combination model, the only truly sealed actuator on the market for extended life. Drum Brake systems come standard with GoldSeal+ combination actuators which set the industry standard for reliable performance.



Haldex Single Piston Caliper

is the industry's lightest weight single piston design with a T-shaped, wide thrust plate to ensure even force distribution and sufficient support to the pad back plate.

Drum Brake Axle is Standard Equipment

The SAF CBX AeroBeam Series standard configuration features a SAF X-Series 5.75" diameter axle with 16½"x 7" extended life brake linings and heavy-duty for both taper and parallel spindles.

SUPERIOR CORROSION PROTECTION



BLACK ARMOUR®
IS STANDARD
WITH CBX SERIES



Optional SAF SC5 Wheel Ends

Now available with our SAF "SC5" wheel end package that provides an engineered solution for a completely dressed drum brake configuration with a 5-year peace of mind warranty.

CBX46 & CBX69

Air Suspension Slider Axle Systems



The SAF CBX Series offers several durable yet lightweight, on/off highway slider suspension axle systems by combining the CBX suspension with proven SAF axle/brake technology.

The SAF CBX46 tandem axle slider suspension delivers one of the lightest weight solutions for on/off highway hauling. Rated for 46,000 lbs. the CBX46 provides fleets with the ability to further maximize their freight capacities where regionally allowed.

The CBX69 slider model features the benefits of a CBX46 in a triple-axle configuration to boost payloads. Tridem provides the versatility to move freight across international, provincial, and state borders while remaining in compliance with bridge/weight regulations.



**CBX46 CAPACITY
46,000 lbs.**

**THE SAF CBX46 AND CBX69 HAVE
THE SAME STANDARD FEATURES
AND OPTIONS AS THE CBX50**



**CBX69 CAPACITY
69,000 lbs.**

Optional P89 Series Air Disc Brakes

Premium Performance Maintenance Free Design

Featuring the legendary INTEGRAL® rotor/hub and premium sealed bearings for reduced maintenance.

Featuring:

- INTEGRAL rotor
- Premium brake chambers
- Robust parallel spindle
- 7-year warranty (see warranty for complete details)
- Long-life sealed bearings
- Haldex calipers and actuators
- Premium spindle nuts

Proven Design Quality with Genuine Value

All the benefits you expect from the world's leading trailer axle disc brake supplier, at a price point that makes sense for commercial fleets of all sizes.

Featuring:

- Heavy-duty vented rotor
- Premium matched set bearings
- Standard 5-year warranty (see warranty for complete details)
- Optional P89 PSP7 wheel end package 7-year warranty (see warranty for complete details)
- Haldex caliper and actuators
- Parallel or taper spindle

**INDUSTRY LEADING
AIR DISC BRAKE
WARRANTY**
See XL-AS11002WC warranty statement for complete details.

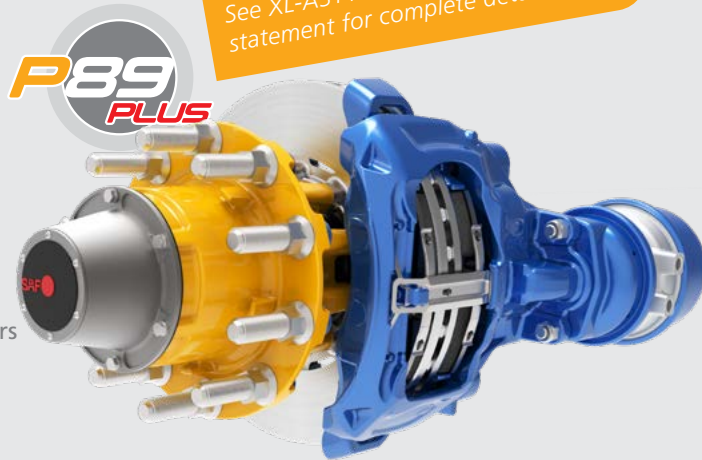

Optional SAF SC7 Wheel End Package

Now available with dressed drum brake configuration, complete your CBX AeroBeam Suspension/Axle system with SAF SC7 wheel ends. Featuring 16½" x 7" extended life brake linings, heavy-duty pre-adjusted hub assembly, optimized bearing spacers, advanced long lasting seals and bearings, and an extended peace of mind 7-year warranty.



Optional SAF SC5 Wheel End Package

Now available with dressed drum brake configuration, complete your CBX AeroBeam Suspension/Axle system with SAF SC5 wheel ends. Featuring 16½" x 7" extended life brake linings, industry standard hub, long lasting seals and bearings, and a peace of mind 7-year warranty.

Optional Enhanced Tire Pressure Management System



The Tire Pilot™ Plus system is now electronically controlled for enhanced fuel economy and tire life.

Optional Tire Pilot™ Plus not only controls pressure through inflation, but also maintains equal pressure across all wheels and features high pressure relief for overinflated tires. The robust design sets it apart from competitive designs with durable components.

- Automatically responds to small leaks caused by road hazards like nails and metal debris.
- System warning light alerts the driver ONLY when there is a need to immediately seek service.
- Diamond knurled hose connections at both hubcaps and tire valve ends allow installation and replacement without a wrench.
- The stainless steel air hose connections are ported through the sides of the hubcap and are protected between the integrated fins.
- High Pressure Relief feature maintains equal and proper pressure for all tires.
- Tire Pilot™ Plus can easily be specified on CBX and ULX Series suspensions, or is available as a simple retrofit on existing trailers.
- Can save over \$750 per year per trailer*.



Proper Air Pressure is Critical to Tire Life

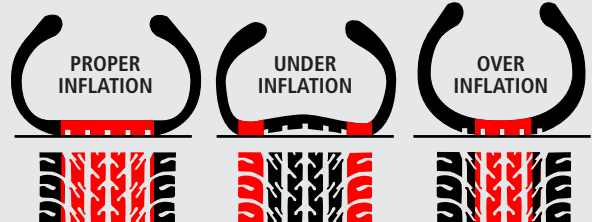

Full Contact
optimizes traction,
handling and
maximizes tire life.

Outside Contact
accelerates irregular
tread wear, increases
rolling resistance, and
reduces fuel efficiency
by up to 2%.

Center Contact
Only reduces tire
life and traction.
Tire is susceptible
to tread damage
and punctures.

* TMC RP235 reports the following – Tires underinflated by 10% will wear 9% to 16% faster than properly inflated tires. Underinflated tires add roll resistance that can reduce fuel economy by as much 2%. The average fleet loses \$750 USD per trailer each year due to improperly inflated tires.

CBX46/50/69 Suspension Specifications

FEATURES	CBX46 AND CBX50		CBX69	
	STANDARD	OPTIONS	STANDARD	OPTIONS
Ride Heights	16", 16½" & 17"	N/A	16", 16½", 17" & 18"	N/A
Slider Width	48"	42" & 54"	48"	42" & 54"
Qwik Release® Pull Arm	•		•	
Air Release		•		•
Swing Align™	•		•	
Height Control Valve with Dump	•		•	
Height Control Valve without Dump		•		•
PosiLok - Anti Dock Walk Device	•		•	
Slider Configured for 6" Center 1¾" Body Rails	•		•	
Slider Configured for 4" Center 1⅝" Body Rails		•		•
Air Tank, Mud Flap & Stinger Brackets		•		•
HOLLAND Slider Rails		•	Order Separately	
Manual Stop Bars		•	Order Separately	

STANDARD DRUM BRAKE AXLE	CBX46 AND CBX50		CBX69	
	STANDARD	OPTIONS	STANDARD	OPTIONS
Axle Track	77½"	77½", 83½"	77½"	71½", 83½"
Spindle	Parallel	Tapered	Parallel	Tapered
Drum Brake	16½" x 7"	16½" x 8⅝"	16½" x 7"	16½" x 8⅝"
Tire Inflation Prep:	Drilled & Tapped Only	•	•	
	Tire Pilot™ Plus	•		•
Extended Life	CBX46	SAF Standard 20k	SAF Standard 23k	NA
	CBX50	SAF Standard 23k	NA	
	CBX69	NA		SAF Standard 23k
Cam Enclosures		•		•
Dust Shields		•		•
SAF SC5 Wheel End Package (5-Year System)		•		•
SAF SC7 Wheel End Package (7-Year System)		•		•

DISC BRAKE AXLE WITH P89 SERIES	CBX46 AND CBX50		CBX69	
	STANDARD	OPTIONS	STANDARD	OPTIONS
Axle Track	77½"	71½", 83½"	77½"	71½", 83½"
P89 (5-year)	•		•	
P89 PSP7 (7-Year)		•		•
P89 Plus (7-Year)	•		•	
Spindle – P89	Parallel	Taper	Parallel	Taper
Spindle – P89 PSP7	Parallel	Taper	Parallel	Taper
Spindle – P89 Plus	Parallel	NA	Parallel	NA
Calipers – Haldex Single Piston	•	NA	•	NA
Tire Inflation Prep:	Drilled & Tapped Only	•	•	
	Tire Pilot™ Plus	•		•
Dust Shields		•		•

Engineering Your Road to Success

The SAF-HOLLAND® Group is one of the leading international manufacturers of suspension-related assemblies and components for trailers, trucks and buses. Our innovative products increase the efficiency, safety and environmental friendliness of commercial vehicles, contribute to the success of our customers. With around 5,500 employees worldwide, we are at the forefront of shaping the future of the transportation industry.



Trailer Axles and
Suspension Systems



Coupling and Lifting
Technologies



Brake Solutions and
Air Valve Technologies



Suspensions and Components
for Commercial Vehicles



Suspensions for
Trucks and Buses



Trailer
Telematics



V.ORLANDI
Coupling and Lifting
Technologies



Trailer Axles and
Suspensions Systems

safholland.com

SAF-HOLLAND, Inc.
Tel 800.876.3929

SAF-HOLLAND Canada Limited
Tel 519.537.3494
Western Canada 604.574.7491

SAF-HOLLAND Mexico
Tel 52.55.5456.8641