

CBXA AeroBeam™ Series

The Industry's Lightest Weight Fixed Frame Trailer Air Suspension Series that Delivers Durability and Proven Performance

The Haldex logo, which consists of the word "Haldex" in white, bold, sans-serif font inside a blue rounded rectangular box.

Featuring Haldex Calipers and Actuators



23K, 25K & 30K CAPACITY
TOP-MOUNT MODELS

CBXA AeroBeam™ Fixed Frame Trailer Air Suspension Axle Systems

The new CBX AeroBeam™ line of fixed suspensions offers the best in top mount design technology with 23,000 lbs., 25,000 lbs. and 30,000 lbs. capacity models. The top mount design features a new lighter weight, more durable cast steel trailing arm and includes proven CBX features such as SwingAlign™, the industry's most accurate axle alignment system, and premium SAF axles with optional P89 disc brakes. The new AeroBeam™ cast trailing arm features an integral shock absorber location to improve ride performance while also creating undercarriage clearance. The versatile model range meets most fleet applications from on-highway, to vocational, to heavy hauling. All models can be equipped with the optional PosiLift™ lift axle mechanism ideal for vocational multi-axle operations.

MODEL CAPACITIES

23,000 lbs. CBXAN23
23,000 lbs. CBXAS23
25,000 lbs. CBXAS25
30,000 lbs. CBXAS30*

SwingAlign™ Axle Alignment

The fastest, easiest and most accurate axle alignment system in the industry. No replacement parts or disassembly is required. Axle alignment adjustment is made directly by the lead screw and permits unmatched alignment accuracy. Requires less than 250 ft. lbs. of torque to adjust.

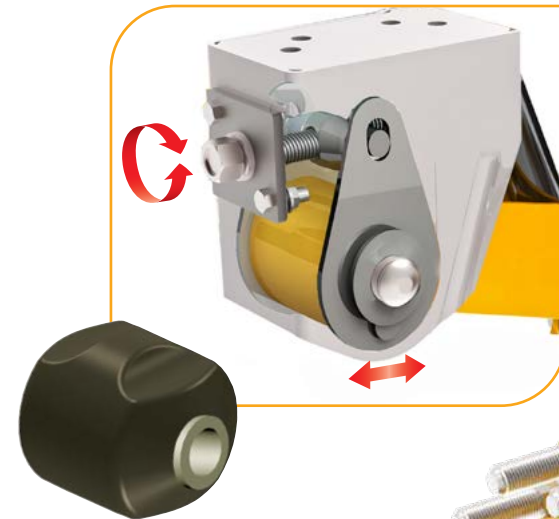

Multi-Functional Pivot Bushing

A robust bushing with its exterior void design limits the twisting movement that could lead to premature bushing and tire wear.

Pivot Connection with Tension Control (TC) Bolt

TC bolt design establishes and maintains proper clamp force on pivot connection assembly. Prevents bushing and frame bracket wear out, avoiding premature tire wear.

Integral Shock Absorber and Trailing Arm Design

Shock is mounted centrally in-line with frame bracket and air spring for optimized ride performance while location maximizes undercarriage clearance.

Lightweight Cast Steel Trailing Arm

Cast beam design meets the demand for durability while providing a low overall system weight.



CBXAS30 Features

Large volume air spring with robust aluminum piston for durability.



Model CBXAN23 Shown

Haldex Spring Brake Actuators

feature the premium LifeSeal+ combination model, the only truly sealed actuator on the market for extended life. Drum brake systems come standard with GoldSeal+ combination actuators which set the industry standard for reliable performance.



Haldex Single Piston Caliper

is the industry's lightest weight single piston design with a T-shaped, wide thrust plate to ensure even force distribution and sufficient support to the pad back plate.

Drum Brake Axle is Standard Equipment

The SAF CBX AeroBeam™ Series standard configuration features a SAF X-Series 5.75" diameter axle with 16½" x 7" extended life brake linings and heavy-duty for both taper and parallel spindles.

OPTIONAL P89 Series™ AIR DISC BRAKES

Two Model Choices to Meet Your Fleet's Specific Needs

The P89 model at a price point that makes sense for fleets of any size. And, the P89 Plus for premium performance. Disc brakes simply provide better performance than drum brakes. They stop shorter for increased safety and reduced maintenance for lower total cost of ownership.

* CBXAS30 Model Rated Suspension Capacity is 30,000 lbs. Axle Capacity is 25,000 lbs.

WHEN EQUIPPED WITH OPTIONAL SAF P89 AIR DISC BRAKES, THE CBX AEROBEAM SERIES PROVIDES THE LIGHTEST WEIGHT FIXED FRAME SUSPENSIONS AVAILABLE.

SUPERIOR CORROSION PROTECTION



BLACK ARMOUR® IS STANDARD WITH AEROBEAM



Optional SAF SC5 Wheel Ends

Now available with our SAF "SC5" wheel end package that provides an engineered solution for a completely dressed drum brake configuration with a 5-year peace of mind warranty.

Optional P89 Series Air Disc Brakes

Premium Performance Maintenance Free Design

Featuring the legendary INTEGRAL® rotor/hub and premium sealed bearings for reduced maintenance.

Featuring:

- INTEGRAL rotor
- Premium brake chambers
- Robust parallel spindle
- 7-year warranty (see warranty for complete details)
- Long-life sealed bearings
- Haldex calipers and actuators
- Premium spindle nuts

Proven Design Quality with Genuine Value

All the benefits you expect from the world's leading trailer axle disc brake supplier, at a price point that makes sense for commercial fleets of all sizes.

Featuring:

- Heavy-duty vented rotor
- Premium matched set bearings
- Standard 5-year warranty (see warranty for complete details)
- Optional P89 PSP7 wheel end package 7-year warranty (see warranty for complete details)
- Haldex caliper and actuators
- Parallel or taper spindle

**INDUSTRY LEADING
AIR DISC BRAKE
WARRANTY**

See XL-AS11002WC warranty statement for complete details.

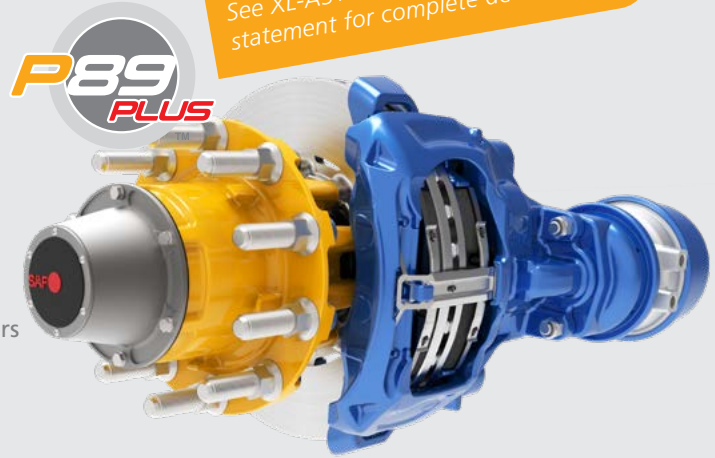

Optional SAF SC7 Wheel End Package

Now available with dressed drum brake configuration, complete your CBX AeroBeam Suspension/Axle system with SAF SC7 wheel ends. Featuring 16½" x 7" extended life brake linings, heavy-duty pre-adjusted hub assembly, optimized bearing spacers, advanced long lasting seals and bearings, and an extended peace of mind 7-year warranty.



Optional SAF SC5 Wheel End Package

Now available with dressed drum brake configuration, complete your CBX AeroBeam Suspension/Axle system with SAF SC5 wheel ends. Featuring 16½" x 7" extended life brake linings, industry standard hub, long lasting seals and bearings, and a peace of mind 7-year warranty.

Optional Tire Pilot™ Plus

Optional Tire Pilot™ Plus not only controls pressure through inflation, but also maintains equal pressure across all wheels and features high pressure relief for overinflated tires. The robust design sets it apart from competitive designs with durable components.

- Diamond knurled hose connections at both hubcaps and tire valve ends allow installation and replacement without a wrench.
- The stainless steel air hose connections are ported through the sides of the hubcap and are protected with integrated fins.
- System warning light alerts the driver only when there is a need to immediately seek service.
- Can save over \$750 per year per trailer.*

* TMC RP235 reports the following – Tires underinflated by 10% will wear 9% to 16% faster than properly inflated tires. Underinflated tires add roll resistance that can reduce fuel economy by as much 2%. The average fleet loses \$750 USD per trailer each year due to improperly inflated tires.

The Tire Pilot™ Plus system is now electronically controlled for enhanced fuel economy and tire life.



Optional Posilift™ Lift Axle System

Light, Durable and Easy to Install

The SAF PosiLift™ Axle Lift System allows operators to easily increase payload with just the flip of a switch.

Featuring:

- Compact design
- Easy to install or retrofit
- Simple under axle lift
- Long life design stabilizing bar

CBL (Center Bag Lift) - Lift axle system is also available as an option.

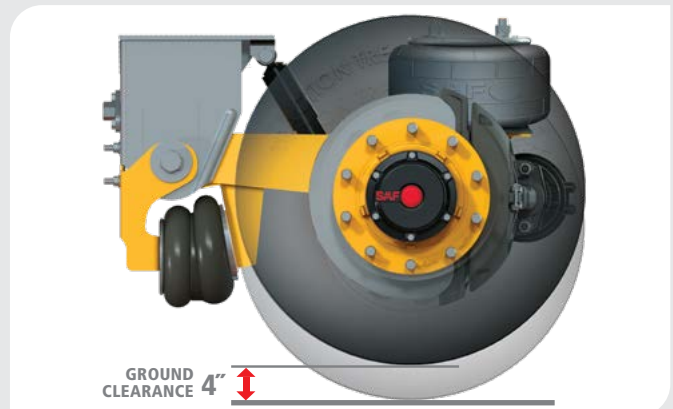
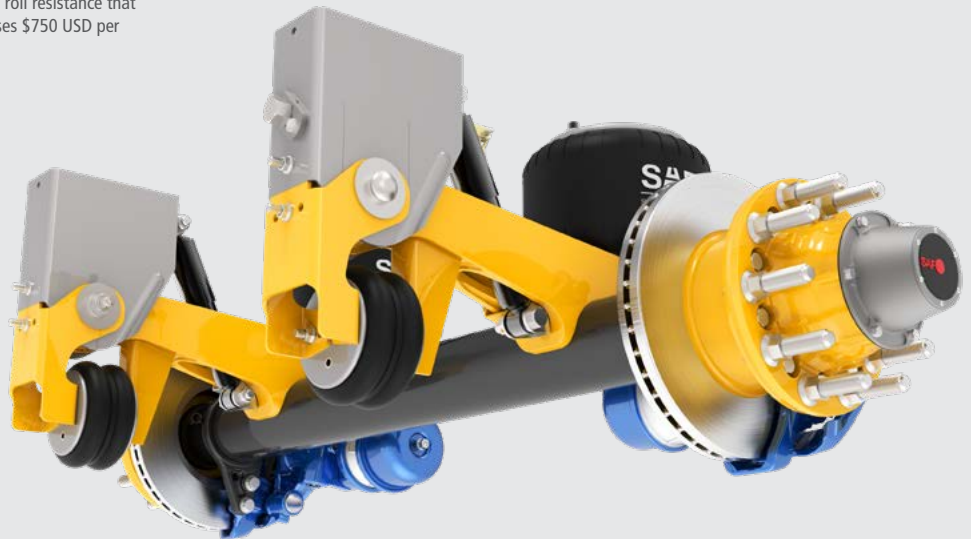

CBXA AeroBeam™ Series Specifications

FEATURES	CBXAN23		CBXAS23	
	STANDARD	OPTIONS	STANDARD	OPTIONS
Ride Heights	14", 15", 16" & 17"	Upon Request	14", 15", 16", 17", 18" & 19"	Upon Request
SwingAlign™	•		•	
Height Control Valve with Dump		•		•
Height Control Valve without Dump		•		•
Upper Air Spring Mounting Plates		•		•
PosiLift™ – Lightweight Lift Axle System		•		•
CBL (Center Bag Lift) - Lift Axle System		NA		NA

STANDARD DRUM BRAKE AXLE	CBXAN23		CBXAS23	
Axle Track	71½"	77½", 81½", 83½" **	71½"	77½", 81½", 83½" **
Spindle	Taper	Parallel	Taper	Parallel
Drum Brake	16½" x 7"	16½" x 8⅝"	16½" x 7"	16½" x 8⅝"
Extended Life Brake Linings	SAF Standard 20k	SAF Standard 23k	SAF Standard 20k	SAF Standard 23k
Tire Inflation Prep:	Drilled & Tapped Only	•	•	
	SAF Tire Pilot™ Plus		•	•
Cam Enclosures		•		•
Dust Shields		•		•
SAF SC5 Wheel End Package (5-Year System)		•		•
SAF SC7 Wheel End Package (7-Year System)		•		•

OPTIONAL P89 SERIES DISC BRAKE AXLE	CBXAN23		CBXAS23	
Axle Track	71½"	77½", 81½", 83½" **	71½"	77½", 81½", 83½" **
P89 (5-Year System)	•		•	
P89 PSP7 (7-Year System)		•		•
P89 Plus (7-Year System)	•		•	
Spindle – P89	Parallel	Taper	Parallel	Taper
Spindle – P89 PSP7	Parallel	Taper	Parallel	Taper
Spindle – P89 Plus™	Parallel	NA	Parallel	NA
Calipers – Haldex Single Piston	•	NA	•	NA
Cambered Axle		•		•
Dust Shields		•		•
Tire Inflation Prep:	Drilled & Tapped Only	•	•	
	SAF Tire Pilot™ Plus		•	•

SUSPENSION SYSTEM WEIGHTS (STANDARD BASE MODEL)*	CBXAN23	CBXAS23	CBXAS25	CBXAS30
Undressed Drum Brake Axle (16.5" x 7" braked axle only – no slack adjusters or brake actuators)	469 lbs.	492 lbs.	524 lbs.	555 lbs.
SAF SC5 Dressed Drum Brake Axle *** (Includes steel hubs/drums, bearings, oil, slack adjusters and brake actuators)	858 lbs.	881 lbs.	913 lbs.	942 lbs.
P89 Disc Brake Axle ****	824 lbs.	847 lbs.	879 lbs.	908 lbs.

* Weights shown for base configuration - 14" ride height, 71½" parallel spindle axles.

** Other axle tracks available upon request.

*** Optional lightweight dressed drum brake wheel ends available - additional 68 lbs. lighter.

**** Optional lightweight disc brake wheel ends available - additional 62 lbs. lighter.

Typical Applications

Versatile CBX AeroBeam™ Fixed Frame Series Suspensions are performance proven for specialty trailer applications. (See suspension application guide)

- Platforms
- Michigan Trains
- Forestry Trailers
- Tank Trailers
- Livestock
- B-Trains
- Dry Bulk
- Grain Hoppers
- Dumps
- Specialty Vans
- Dollies & Pups
- Container Chassis

CBXAS25		CBXAS30	
STANDARD	OPTIONS	STANDARD	OPTIONS
14", 15", 16", 17", 18" & 19"	Upon Request	14", 15", 16", 17", 18" & 19"	Upon Request
•		•	
	•		•
	•		•
	•	•	
	•		•
	•		•

CBXAS25		CBXAS30	
71½"	77½", 81½", 83½" **	77½"	71½", 81½", 83½" **
Taper	Parallel	Taper	Parallel
16½" x 7"	16½" x 8⅝"	16½" x 7"	16½" x 8⅝"
SAF Standard 23k		SAF Standard 23k	
•			•
	•		•
	•		•
•		•	
	•		•
	•		•

CBXAS25		CBXAS30	
71½"	77½", 81½", 83½" **	77½"	71½", 81½", 83½" **
•		•	
	•		•
•		•	
Parallel	Taper	Parallel	NA
Parallel	Taper	Parallel	NA
Parallel	NA	Parallel	NA
•	NA	•	NA
NA	NA	NA	NA
	•		•
•		•	
	•		•

Frame Bracket Options

CBXAN23 – Weld-On, Weld-On with Wing, Bolt-On, Stainless Steel Weld-On & Tapered Top Weld-On

CBXAS23, CBXAS25 & CBXAS30 – Weld-On, Weld-On with Wing & Bolt-On

NOTE: CBXA AeroBeam number designations **AN & AS**
A - Designates AeroBeam style cast beam
N - Designates Narrow frame bracket
S - Designates Standard frame bracket

Engineering Your Road to Success

The SAF-HOLLAND® Group is one of the leading international manufacturers of suspension-related assemblies and components for trailers, trucks and buses. Our innovative products increase the efficiency, safety and environmental friendliness of commercial vehicles, contribute to the success of our customers. With around 5,500 employees worldwide, we are at the forefront of shaping the future of the transportation industry.



Trailer Axles and
Suspension Systems



Coupling and Lifting
Technologies



Brake Solutions and
Air Valve Technologies



Suspensions and Components
for Commercial Vehicles



Suspensions for
Trucks and Buses



Trailer
Telematics



V.ORLANDI
Coupling and Lifting
Technologies



Trailer Axles and
Suspensions Systems

safholland.com

SAF-HOLLAND, Inc.
Tel 800.876.3929

SAF-HOLLAND Canada Limited
Tel 519.537.3494
Western Canada 604.574.7491

SAF-HOLLAND Mexico
Tel 52.55.5456.8641