



FIFTH WHEELS

INSTALLATION INSTRUCTIONS FIXED MOUNTINGS



Holland Eurohitch Fifth Wheels

Installation Instructions Covering ISO bracket and Weightsaver Stationary (fixed) Mountings

GENERAL INFORMATION



WARNING

Failure to read, understand and follow the important information contained in these instructions may result in a hazardous condition or cause a hazardous condition to develop



WARNING

When welding, use a procedure which assures a sound, good quality weld and which protects operators and others. Overwelding may cause distortion and damage, and underwelding may not develop sufficient strength.

Welding procedures EN499-E 42 0 RR 1 2 (electrode) or EN440-G 42 0 G3Si1 (gas) are recommended. Take precautions to ensure that the tractor electrical system is not damaged during the welding process.

FIFTH WHEEL DESIGN AND INTENDED USE

Holland Fifth Wheels are Designed and Intended to be Used :

1. For pulling trailers with standard ISO king pins which are in good condition and securely mounted or locked in position in the trailer
2. Within the capacities stated in Holland literature
3. As recommended in Holland literature (available from Holland and/or Holland distributors)

Holland Fifth Wheels are NOT Designed or Intended For :

1. Use with non-ISO king pins, such as king pins which are bent, improper size or dimensions, not secured to maintain ISO configuration, or which are installed in warped trailer skidplates
2. Tow-away operations which damage or interfere with the proper operation of the fifth wheel
3. The attachment of lifting devices
4. The transportation of loads in excess of rated capacity
5. Applications other than recommended

RATINGS AND CAPACITIES

The tractor/trailer combination to be operated must be within the Gross Combination Weight, Vertical Load and D-Value Capacities given in the Holland specification for the fifth wheel concerned.

To calculate the D-value for a tractor and semi-trailer combination use the following formula

$$D = g \times \frac{0.6 \times T \times R}{T + R - U} \quad (\text{kN})$$

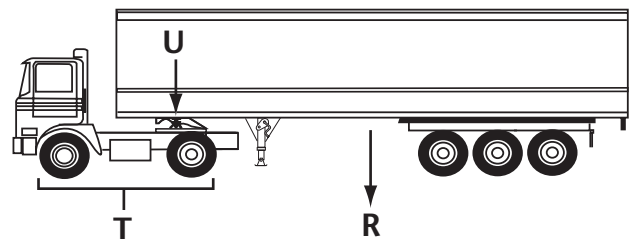

T = Weight of towing vehicle including the vertical load on the fifth wheel

R = Total weight of the loaded semi-trailer

U = Vertical load on the fifth wheel

g = Acceleration due to gravity (assumed to be 9.81 m/s²)

Example calculation :

T = 17 (Tractor weight 7t plus vertical load 10t)

R = 33 (10t imposed on fifth wheel and 23t on rear bogie)

U = 10

g = 9.81

$$D = 9.81 \times \frac{0.6 \times 17 \times 33}{17 + 33 - 10} \quad (\text{kN})$$

D-Value = 82.55 kN

The above calculation represents a 2 axle tractor with tri-axle trailer operating at a GCW of 40000 kg

For safe operation the D-value calculated must not exceed the D-value rating of the Fifth Wheel and/or King Pin

GENERAL RECOMMENDATIONS

1. Every user and installer using Holland products either recommended or not recommended by Holland, must thoroughly satisfy himself that the installation procedure used is appropriate for the vehicle, product and application
2. Consult the Holland literature for fifth wheel capacities and applications
3. Consult the tractor manufacturers instructions and any applicable government and/or transport department guidelines and regulations where the vehicle is to be registered and/or operated
4. Determine the proper fifth wheel position which is important for weight distribution, swing clearance and handling characteristics. Consult the tractor manufacturers recommendations



WARNING

The centre of the king pin locks must always be positioned ahead of the tractor rear axle or bogie centre line

5. Bolt holes can be 2 mm larger in diameter than the bolt fastener. Bolts must be adequately tightened using charted torque ranges in Nm for the recommended grade and size of bolts used

STANDARD ISO MOUNTING

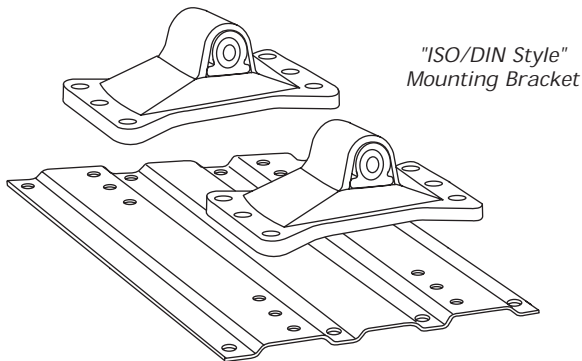

1. All ISO bracket mounted fifth wheels are fitted with 6 hole mounting brackets with a hole pattern to DIN 74081
2. The fifth wheel should be mounted onto the tractor chassis using a suitable / approved mounting plate which complies to the recommendations of the truck manufacturer and any applicable local regulations
3. The fifth wheel should be secured to the mounting plate using 12 bolts M16 grade 8.8 (min.) or grade 10.9 (rec.)
4. The mounting plate should be secured to the chassis mounting angles using a minimum of 6 bolts per side M16 grade 8.8, or alternatively 4 bolts per side, M16 grade 10.9 or M20 grade 8.8
5. The fifth wheel mounting brackets and/or mounting plate can be secured against lateral and longitudinal movement by welded stops if required (see illustration on opposite page)

INSTALLATION



WARNING

The installation of the fifth wheel and mounting plate on the vehicle must conform to EC regulation 94/20 EG appendix VII, (see appendix I, No. 5.10)

NOTE: These instructions are based on the tractor unit being fitted with outboard 'L' profile mounting angles (fitch plates). Please contact Holland Europe if your tractor unit is not fitted with mounting angles

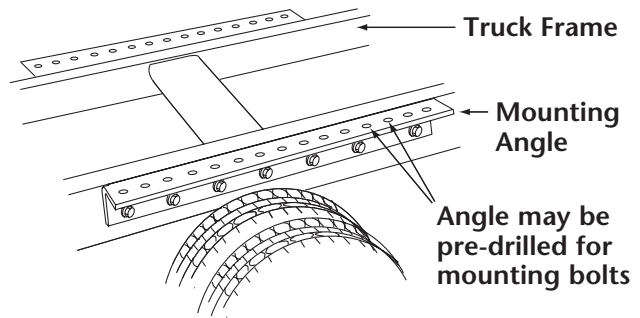

WARNING

In addition to these recommendations, all fifth wheel mounting plate installations must be made in accordance with all applicable government regulations where the vehicle is registered and/or operated.

ISO / DIN HOLE PATTERN

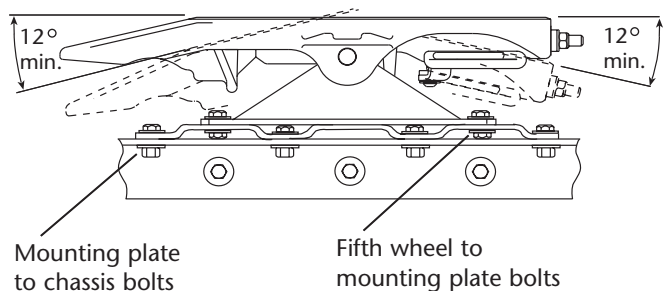
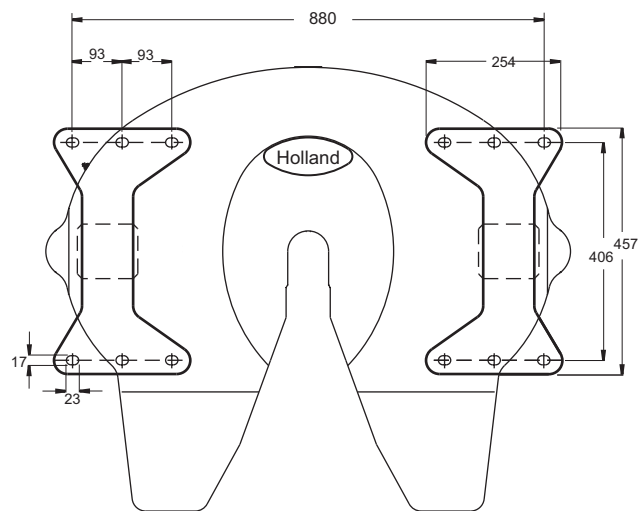

WEIGHTSAVER MOUNTING

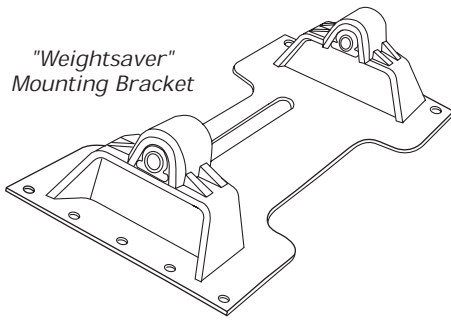

1. The Weightsaver mounting uses an integral bracket and baseplate and should be bolted directly to the mounting angles on the truck chassis
2. The bolted joints must be properly torqued as shown below and checked for a secure installation
3. The fifth wheel must be mounted in such a way that the top plate is free to articulate about the brackets to the recommended minimum of all applicable regulations including ISO 1726
4. The Weightsaver baseplate can be secured against longitudinal and lateral movement through the use of welded stops. This may be a requirement of the tractor manufacturer or a government regulation
5. Minimum baseplate attachment requirements (per side) :

5 bolts M16 x 1.5 (min. grade 8.8)
 4 bolts M16 x 1.5 (min. grade 10.9)
 4 bolts M20 x 1.5 (min. grade 8.8)

6. Correct tightening torque :

M20 x 1.5 - 8.8	460 Nm
M16 x 1.5 - 10.9	315 Nm
M16 x 1.5 - 8.8	225 Nm

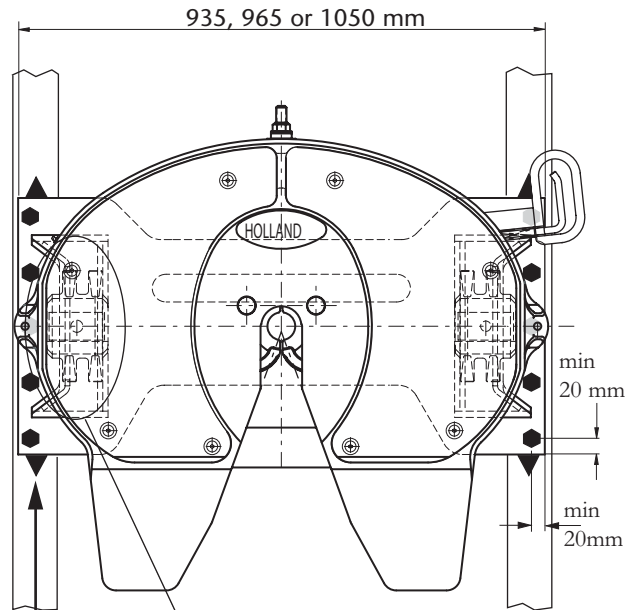

Note: Bracket mounting on chassis area

Welded stop if required

Welding procedure : EN 499-E or EN 440-G
 Filler Material : E 4320 B9 DIN 1913
 alternatively
 Welding procedure: MAG C
 TÜV approved filler material

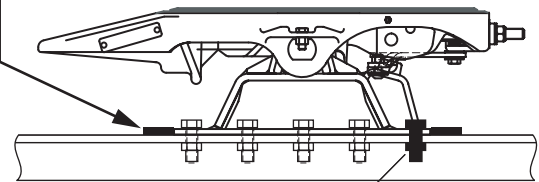

Tighten to correct torque setting

HEAVY DUTY INSTALLATIONS

The weightsaver mounting must not be used for installations above 65000 kg GCW. For these application ISO bracket mounting should be used.

1. For operation above 65000 kg the fifth wheel should be secured to the mounting plate using 12 bolts M16 grade 10.9 mounting bolts
2. Additional mounting bolts will be required for installations above 65000 kg GCW

CONSULT THE TRUCK MANUFACTURER !

3. For operation above 65000 kg some truck manufacturers require an extended subframe / baseplate assembly to be fitted to spread the load along the truck frame (see opposite)

CONSULT THE TRUCK MANUFACTURER !

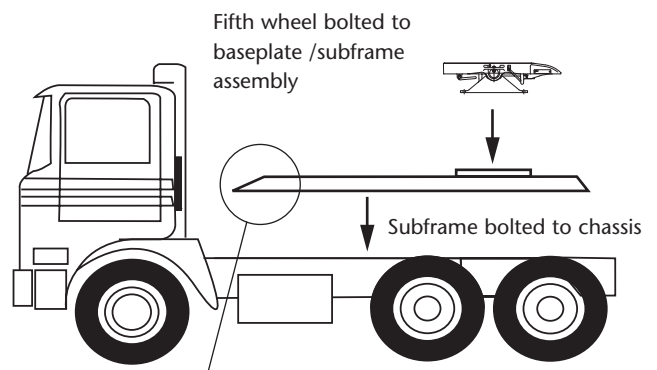

A flexible body style mounting is normally used at the front end of the extended subframe to prevent excessive stress in the tractor frame

INSPECTION AND LUBRICATION

The fifth wheel must be given a final inspection and be fully lubricated before going into service.

1. Review the installation. Be sure that all nuts and bolts are in place and properly tightened. Be sure that all necessary steps were followed and that any components removed to facilitate installation are reinstalled
2. Check the fifth wheel locking mechanism with a Holland lock tester and examine for proper locking as described in the *Fifth Wheel Operating Manual* supplied with your fifth wheel. This must be done to ensure that the fifth wheel has not been damaged during shipment or installation
3. Lubricate all moving parts with a light oil.
4. Apply grease to bearing surface of mounting bracket where applicable and where a grease fitting is provided on the fifth wheel pocket. The top plate should be lifted up to relieve weight on the bracket while the grease is applied. (not required on fifth wheels fitted with pocket inserts)
5. On standard fifth wheels apply a generous coating of grease to the top surface of the fifth wheel where it will contact the trailer skidplate. On low maintenance fifth wheels fitted with wear pads coat the wear pads with a light oil to assist the bedding in process



WARNING

The fifth wheel locking mechanism must be checked prior to use. Do not use any fifth wheel which does not operate properly

IMPORTANT NOTE : PLEASE ENSURE THAT THE FIFTH WHEEL OPERATING MANUAL SUPPLIED WITH THE FIFTH WHEEL IS PASSED ONTO THE OPERATOR AND THAT IT IS READ AND UNDERSTOOD BY THE OPERATOR AND DRIVERS

Contact Holland for additional copies if required

Copyright © June 2004 • The Holland Group Inc.



The Holland Group, Inc.
Holland, MI 49423
United States
Phone: (616) 396-6501
Fax: (616) 396-1511

EN ISO
9001:2000



DNV
Certified
Company

Holland Europe GmbH

Altenkamp 9
D-33758
Schloss Holte-Stukenbrock
Germany

Phone: +49 (0) 5207-89560
Fax: +49 (0) 5207-895656

Holland Eurohitch Ltd.

Hoo Farm Industrial Estate
Worcester Road
Kidderminster
Worcestershire
DY11 7RA

Phone: +44 (0) 1562-732010
Fax: +44 (0) 1562-732020

Holland Hitch (Aust.) Pty. Ltd.

Melton, Victoria, Australia
Phone: 61-(0)3-9743-6799
Fax: 61-(0)3-9747-9617

Holland Transtrade

(Thailand) Company, Ltd.
Bangkok, Thailand
Phone: 66 (0)2-513-8758
Fax: 66 (0)2-513-8757

Nippon Holland, Ltd.

Tokyo, Japan
Phone: 81-(0)3-3461-9130
Fax: 81-(0)3-3463-1407

Holland Transtrade

Far East SDN BHD
Shah Alam, Malaysia
Phone: 60 (0)3 734-2888
Fax: 60 (0)3 736-5588